



Vehicle combinations based on the modular concept

Background and analysis

John Aurell & Thomas Wadman, Volvo Trucks

Report no. 1/2007

Committee 54: Vehicles and Transports

Author: John Aurell and Thomas Wadman, Volvo Trucks, Sweden

Title: Vehicle combinations based on the modular concept

Series: NVF-reports

ISSN: 0347-2485

The NVF-reports may be ordered from the NVF-secretariats. See contact information on the second last page.
There is an updated record of NVF-reports on <http://www.nvfnorden.org>.

Vehicle combinations based on the modular concept

Background and analysis

John Aurell & Thomas Wadman, Volvo Trucks

Report nr. 1/2007
Committee 54: Vehicles and Transports

Summary

This report describes the development of weights and dimensions of heavy vehicles in Europe. It illustrates the background to the modular concept (EMS) and explains the advantages with the modular concept. The report provides an extensive analysis of the performance of a large number of conventional and modular vehicle combination types.

Sammanfattning

Föreliggande rapport beskriver hur vikter och dimensioner hos tunga fordon i Europa har utvecklats. Den belyser bakgrunden till modulsystemet (EMS) och redogör för dess fördelar. Rapporten innehåller en omfattande analys av prestanda hos ett stort antal fordonskombinationstyper, både konventionella och sådana baserade på modulsystemet.

Yhteenveto

Raportti kuvailee raskaiden ajoneuvojen painon ja koon kehitystä Euroopassa. Se valottaa moduulijärjestelmän (EMS) taustoja ja tuo esille sen hyötyjä. Raportti sisältää kattavan analyysin monen sekä perinteisen että moduulijärjestelmään perustuvan ajoneuvoyhdistelmätyypin suorituskyvystä.

Content

1	Weight and dimension in retrospect	11
1.1	European perspective	11
1.2	Long vehicle combinations outside of Europe	14
2	The modular concept	16
2.1	Background	16
2.2	Description of the modular concept	18
2.3	Advantages with the modular concept	20
3	Stability performance measure of vehicle combinations	22
4	Swept path performance measure of vehicle combinations	24
5	Road wear performance measure of vehicle combinations	26
6	Mathematical vehicle model	27
7	The modular concept as applied in the Nordic countries	27
7.1	Vehicle specifications	28
7.2	Performance	34
8	Prospective modular vehicle combinations	37
8.1	Vehicle specifications	38
8.2	Performance	41
9	Parameter study	44
9.1	Tractor – semitrailer (#2)	44
9.2	Truck – centre-axle trailer (#3)	46
9.3	Truck – full trailer (#4)	49
9.4	Tractor – semitrailer – centre-axle trailer (#5)	51
9.5	Truck – dolly – semitrailer (#6)	53
9.6	B-double (#8)	54
9.7	Double centre-axle trailer (#12)	56
9.8	Summary of parameter study	59
10	Conclusions	60
11	References	62

1 Weight and dimension in retrospect

1.1 European perspective

As the need for more transportation of goods developed, both the size and weight of heavy vehicles increased in Europe. Each country had their own regulations. When trade and transports became more international, there was however also a need for harmonization of weights and dimensions of heavy vehicles. In 1963, EEC made its first effort to propose a directive that specified weights and dimensions. This was however a long process, and not until 1985 the first directive, 85/3 EEC, that regulated weights and dimensions for international traffic between member countries, appeared.

1.1.1 Weight

The load of non-driving single axles was generally limited to 10 t. The same limit applied to driving axles in Northern Europe, while Southern Europe allowed 12-13 t. There was a corresponding difference for tandem axles. When 10 t was allowed on driving single axles, 16 t was allowed on tandem axles. There were exceptions; NL permitted 18 t and GB 18,5 t. Countries allowing the higher driving-axle load allowed 18-21 t on tandem axles. Finally a compromise was achieved in directive 85/3 EEC, and the following axle loads were agreed for international traffic.

single non-driving axles: 10 t

tandem axles of trailers: 16-20 t, depending on axle distance

triple axles of trailers: 21-24 t, depending on axle distance

The maximum gross-combination weight was in this directive set to 40 t for a vehicle combination with five axles. 44 t GCW was allowed for transports of 40-foot ISO containers in a combined transport operation. The tractor must then have at least three axles, and the whole combination shall have at least five axles.

There were many things missing in directive 85/3 EEC, and it was amended for the first time already in 1986, with Amendment 86/360 EEC. Here the allowed single-driving-axle load was set to maximum 11,5 t in international traffic. There was however a long transitional period until 17th January 1992.

Another amendment to directive 85/3 EEC, 89/338 EEC, was published in 1989. In this amendment the maximum allowed tandem-axle load is set to 18 t, if the axle distance is between 1,3 and 1,8 m. However, if the driving axles have "road-friendly suspension", 19 t tandem-axle load is allowed. "Road-friendly suspension" implies that the driving axles are fitted with twin tyres and air suspension or suspension recognized as being equivalent to air suspension within the community. The word "road-friendly suspension" is not used in the directive.

This amendment also sets the maximum gross-vehicle weight for two-axle motor vehicles to 18 t. The GVW for three-axle motor vehicles is 25 t, or 26 t if the driving axles have road-friendly suspension. The maximum authorized weight for four-axle motor vehicles with two steering axles is 32 t, provided the driving axles have "road-friendly suspension" and the bridge formula is fulfilled. The bridge formula states that the maximum authorized weight may not exceed five times the distance in metres between the axes of the foremost and rearmost

axles of the vehicle. There is also a bonus of 2 t on the GCW for vehicle combinations consisting of two-axle tractor and two-axle semitrailer, if the driving axle has “road-friendly suspension”. There was a long transitional period for these changes until 1992.

So far “road-friendly suspension” was not quantitatively defined. This was done in Amendment 92/7 EEC, which was published in 1992. Here “equivalence to air suspension” was defined as follows.

- The frequency of the sprung mass above the driving axle or bogie in a free transient vertical oscillation must not be higher than 2,0 Hz.
- The mean damping ratio, D, must be more than 20 % of critical damping for the suspension in its normal conditions with hydraulic damper in place and operating.
- The damping ratio of the suspension with all hydraulic dampers removed or incapacitated must be not more than 50 % of D.
- A tandem-axle suspension is also considered to be equivalent to air suspension if the static load on the axles is equalized.

The requirements in this amendments were to apply before 17 January 1993 in the member countries.

1.1.2 Length of tractor–semitrailer vehicle combinations

Before 1985 most countries had limited the total length to 15 m. The semitrailers had normally two axles and the tractors were equipped with three or two axles. A normal length of the semitrailers was around 11 m but with a tendency to increase. The introduction of 40 foot containers required a total length of 15,5 m. Many countries therefore allowed longer vehicle combinations if the semitrailer had container locks. As a result of these needs, Directive 85/3 set the maximum authorized length to 15,5 m for international traffic. This total length gave a possible loading length of up to 12,75 m, which allows the transportation of 31 EU-palletes. After 1985 the concept with two-axle tractor and three-axle semitrailer became the standard configuration. The directive also introduced a turning circle requirement that maximizes the swept path width to 7,2 m in a 360 degree turn on a 12,5 m outer radius. In an effort to increase the loading length, the semitrailers were made longer. In order to make that possible, short cabs with topsleeper were introduced. The tractors were also optimized with respect to cab space in order to accommodate for a semitrailer length up to 13,6 m within the total length of 15,5 m.

The amendment 89/461 EEC started a new way of thinking. The total length was increased to 16,5 m, but at the same time the length of the semitrailer, i.e. the loading length, was maximized to approximately 13,6 m. It now no longer paid to increase the loading length at the expense of the driver environment. It was possible to use a sleeper cab with the bunk behind the seats. The load-carrying capacity now increased to 33 palletes on a semitrailer. It is even possible to load 34 palletes if the front of the semitrailer is given a circular shape. This obviously reduced the difference to truck/full trailer and truck/centre-axle trailer combinations, and as a result the proportion of tractor/semitrailer combinations increased. To be able to take advantage of the new possibilities required both tractors with longer wheelbase and new semitrailers. Many operators had the residual value of their vehicles drastically reduced.

1.1.3 Length of rigid truck–trailer vehicle combinations

Up to 1985 most countries allowed a total length of around 18 m. Some Nordic countries like Finland and Sweden allowed 22 respectively 24 m. 18+2 % (18,35 m) total length was

however more or less a standard in Europe. With a classic full trailer and a gap between truck and trailer of 1,4 m, a loading length of 14,4 m was achieved. With other words 34 EU-palettes could be carried. Directive 85/3 EEC regulated the total length to 18,00, but many operators continued to use 18,35 m combinations.

The competition hardened between international transporters in the second part of the eighties. Dutch transporters started to use very short day cabs with a sleeper box on the roof of the cab. This was a way to increase the load length. Centre-axle trailers were also introduced, because then the load length could be maximized within 18 m total length. The smallest gap, between truck and trailer, was 0,7 m. Another step in the same direction was the introduction of extendable short-coupling systems. The gap was then minimized to 0,35 m when the vehicle was driven straight ahead. When cornering the distance increased to make it possible to turn. Swap bodies were frequently used on centre-axle trailers and one additional way of extending the loading length was to let the swap body stick out behind the rear of the trailer, claiming the swap body was part of the load and allowed outside the length limit. This is to twist the regulation beyond the limits of reason but was approved by Dutch authorities.

The never-ending effort to maximize the loading length led to the design of extremely short cabs, with very little space for the driver, so called letter-box cabs. By doing these changes and using short couplings, it was possible to transport two 8,22 m swap bodies, containing 40 EU-palettes.

At the same time swap bodies were being standardized within CEN. Four different lengths, 7,15, 7,42, 7,82 and 8,22 m, were proposed. All except 8,22 m were approved by CEN as standard.

In 1991 one more amendment to Directive 85/3 EEC was published. Amendment 91/60 EEC finished the top-sleeper era. The total length was increased to 18,35 m, and most important, the maximum loading length was set to 15,65 m. The maximum distance from the foremost external point of the loading area behind the cab to the rearmost point of the trailer of the combination was set to 16,00 m. Consequently, reducing the space in the cab gave no longer benefits in terms of loading length. This was a success for those who cared for the driver environment. A long cab was possible without reducing the loading length and gave the possibility to have a conventional sleeper cab with the bed behind the seats.

With maximum loading length there was however still not more than 0,35 m gap between truck and trailer. Extendable short couplings were still necessary, and the discussions in Brussels went on. Finally, in 1996, a new directive replaced Directive 85/3 and all its amendments. Directive 96/53 EC increased the total length to 18,75 m and the length between the front of the loading area and the rear of the loading area to 16,40 m. The effective loading length was kept at 15,65 m. This gave the possibility to have a fixed coupling.

1.1.4 Width and height

The general vehicle width was 2,50 m since at least the sixties. This makes it however difficult to load three EU-palettes side by side. Sweden, the Netherlands, Belgium and Finland therefore increased the total width to 2,60 m during the eighties.

The width 2,50 m gives a even more serious problem for refrigerated transports. In order to allow loading of EU-palettes, the insulation may not be more than 30 mm. Then there is not much space left to allow for airflow between the sidewalls and the refrigerated goods.

Amendment 88/218 EEC, published in 1988, increased the total width of the superstructure to 2,60 m for refrigerated vehicles. This allows for 45 mm thick insulated walls, which solved the problem for refrigerated transports.

The total width for the remainder of vehicles stayed however at 2,50 m. The transporters struggled and it became common to take advantage of the German width tolerance and build 2,53 m wide vehicles.

Finally Directive 96/53 EC increased the general width to 2,55 m. This makes the internal space comparable for both refrigerated and non-refrigerated vehicles.

The maximum authorized height for international traffic was set to 4,0 m in Directive 85/3 EEC and was later confirmed in Directive 96/53 EC. This height is also the maximum for transports on railroads in combined traffic. The directive allows higher vehicles in national transports and for modular combinations. In most countries, however, 4,0 m maximum height is also used for national traffic as large parts of the infrastructure does not allow higher vehicles.

1.1.5 Turning circle

Some countries, like Germany had a turning circle requirement, "BO-Kraftkreis". This requires that any vehicle shall be able to turn within a circle with a radius of 12,5 m with a swept path width of maximum 7,2 m. This requirement was adopted into Directive 85/3 EEC and transferred to Directive 96/53 EC. It does not apply to modular vehicle combinations.

1.1.6 Driving-axle load

Directive 85/3 stated that the weight carried by driving axles must be at least 25 % of the total laden weight in international traffic. Directive 96/53 EC kept this requirement.

1.2 Long vehicle combinations outside of Europe

Longer vehicle combinations than in Europe are used in some countries in North and South America, Africa, Australia and New Zealand.

The most common combination types are A-double and B-double, but also C-double and truck–full trailer occur. Occurring vehicle-combination types are described for each country. Maximum authorized lengths and weights are shown in Table 2. Table 1 shows definitions of some terms used for vehicle combinations.

Table 1– Definitions

A-double	consists of tractor , semitrailer and full trailer.
Full trailer	has both front and rear running gear, but may also consist of a converter dolly and semitrailer.
B-double	consists of tractor, semitrailer with a fifth wheel and semitrailer.
C-double	consists of tractor, semitrailer, C-dolly and semitrailer.
C-dolly	is a converter dolly where the coupling of drawbar has only pitch degree of freedom and the axle is steered

1.2.1 Australia

There is a large number of various combination types, A-double, A-triples, B-doubles, B-triples and a mixture of all that are driven with special permit. The longest ones are more than 50 m long and weigh more than 100 t. They are coupled up in special locations from several other vehicle combinations and driven in remote areas. The most common long vehicle combination that is driven without restrictions on most roads is a B-double. The tractor has two driving axles and the total number of axles is nine. There is no margin at all for uneven load distribution.

1.2.2 Brazil

The most common long vehicle combination is a B-double. It uses a three-axle tractor with two driving axles. There are altogether 7 axles. No margin for uneven load distribution exists.

1.2.3 Canada

Long vehicle combinations occur frequently. There are both A-doubles and B-doubles as well as C-doubles. They have all the same length, but the gross combination weight varies with the number of axles. A B-double combination is the heaviest one and has eight axles. The tractor has two driving axles. In this case there is no margin for uneven load distribution. The lower value for the steer axle load applies to tractors and the higher to rigids.

1.2.4 New Zealand

Vehicle combinations longer than in Europe are frequently used. Both A-doubles and B-doubles as well as truck–full trailer combinations are used. Two driving axles are required for GCW over 39 t. The most popular combination type is a B-double with eight axles. It has a very good margin for uneven load distribution.

1.2.5 South Africa

There is one long vehicle combination and this is a B-double. The tractor has two driving axles and the vehicle combination has altogether seven axles. There is a certain margin for uneven load distribution.

1.2.6 USA

The total length is not regulated, but only the loading length. Long vehicle combinations are however not used in interstate traffic. Different states have their own regulations and long vehicle combinations of different lengths are used. They are combined of semitrailers of different standardized lengths. The most common vehicle combinations are A-doubles. The tractors have two driving axles.

Table 2 – Lengths and weights of non-European long vehicle combinations

Country	Total length (m)	GCW (tonnes)	Axle load (tonnes)			
			Steer axle	Single axle	Tandem axle	Triple axle
Australia	26	62,5	6	9	16,5	20
Brazil	19,8	57	6	10	17	25,5
Canada	25	62,5	5,5/7,3	9,1	17	21
New Zealand	20	44	6	8,2	15	18
South Africa	22	56	7,7	9	18	24
USA	20-40	63,5	5,7	9,1	15,4	-

2 The modular concept

Directive 96/53 EC, Article 4, gives the possibility for each member country in the European Union to use longer vehicle combinations as long as they are based on the modular concept. This agreement was the result of a long process, where the main actors were Volvo Trucks, the Swedish road authorities together with the Swedish government and the EU Commission.

2.1 Background

Long vehicle combinations have a long history in Sweden, and there was no limit on the total length of vehicle combinations before 1968. Quite a few were 30 m and longer. The most common length for long haul vehicles was however 24 m, and the most common combination type was truck and full trailer. In 1968, with a transition period to 1972, the maximum authorized total length was set to 24 m.

In the same year, the Swedish Road and Transport Research Institute published an extensive report on dynamic stability of a large number of vehicle combinations. The results in this report were mainly based on computer simulations with validated mathematical vehicle models. Various performance measures in a special double lane-change manoeuvre were suggested.

In 1977, the Swedish government proposed to reduce the maximum authorized vehicle combination length to 18 m in the belief that this would increase the traffic safety. The proposal received however no support, as it could be shown that the result would have been the opposite.

In the 1980's there were several projects in Sweden concerned with innovative long vehicle combinations, some of them with Volvo involvement. Various concepts of vehicle combinations with double semitrailers were constructed, tested and used in real operations.

A TFK-project, also with Volvo participation, concerned with simulations, experiment and field tests of various vehicle combination types took place. In this program, there was a certain focus on the vehicle behaviour on snow and ice surfaces. An extensive program of analytical and experimental studies of the dynamic stability of vehicle combination started at Volvo during the 1980's.

The important idea of the modular concept was borne in the 1980's at Volvo.

The first European directive on Weight and Dimension appeared in 1985. It regulated the maximum total length of vehicle combinations to 18 m. It was however only concerned with international traffic and therefore had no impact on the length of vehicle combinations used only nationally.

After having increased the authorized combination weight, the accident rate with truck – full trailer combinations increased in Norway in 1987. Volvo presented findings from dynamic stability studies on a Norwegian seminar, which eventually resulted in increased permitted total length.

Swedish regulations allowed the use of two trailers in a vehicle combination, but only with reduced speed, 40 km/h. In 1989, a new regulation allowed the same speed as other vehicle combinations, if double combinations fulfilled certain stability requirements.

In 1989 and in 1991, the important concept of maximized loading length was amended to Directive 85/3 EEC for tractor-semitrailer combinations respectively truck-trailer combinations. This was the beginning of modular loading lengths.

In 1991, the EU commission proposed to let the weight and dimension rules for international traffic apply also to national traffic. The reason for harmonizing also national traffic was for the benefit of competition across the borders. The weight harmonization in national traffic was opposed by many countries, while length harmonization was opposed only by Finland and Sweden. It would have led to that the length of vehicle combinations in Sweden and Finland would have been reduced from 24 m respectively 22 m to 18,35 m, and the gross combination weight from 60 t to 40 t..

In 1992, Volvo presented the first proposal of the modular concept to Swedish authorities, government and industry.

In 1993, Volvo presented the proposal of the modular concept to Luc Werring and John Berry in the EU commission.

There were shared opinions on the modular concept in Sweden. Nevertheless, in 1993 the Swedish minister of transport presented the proposal in Brussels.

In 1994, ACEA presented its future vision in a document, "Trucks and their environment the road ahead", that supported the modular concept. The same year, the EU commission presented an updated proposal of the new Weight and Dimension directive that included the modular concept.

One of the major concerns with the modular concept was traffic safety, in particular dynamic stability. Volvo had therefore been carrying out extensive analyses and tests of the dynamic stability of current EU vehicle combinations and modular combinations. A paper on the modular concept was presented at the Fourth International Symposium on Heavy Vehicle Weights and Dimensions in 1995. The same year, Luc Werring requested Volvo to share the results of their studies with the Finnish government in order to facilitate the Finnish decision on the modular concept. Further on that year IRU expressed their support of the modular concept.

In 1996, Volvo presented the modular concept to European motor journalists, and participated in a special Trans-Euro test of modular vehicle combinations in comparison with conventional vehicle combinations. The test was carried out in Spain. The result was met with great interest and enthusiasm throughout the European press.

Many member states were critical of in any way permitting derogations from the lengths allowed for international traffic. This made the wording in the part of the directive concerned with the modular concept crucial. On the basis that operators from all countries would be competing under equal conditions, agreement was however finally reached, and the new directive on weights and dimensions, Directive 96/53 EC, was published in 1996, including the possibility to use long vehicle combinations based on the modular concept. No harmonization of weights or axle loads were however included in the directive. This was not considered being crucial for equal conditions of competition.

Work was simultaneously going on within ISO/TC22/SC9/WG6 in order to standardize methods for testing dynamic stability of vehicle combination, and the standard was published in 1997.

In 1997, the modular concept was introduced in both Finland and Sweden. The Finnish and Swedish regulations were very well harmonized. This was the first implementation of the modular concept.

2.2 Description of the modular concept

The modular concept is defined in Directive 96/53 EC, Article 4, § 4 (b) as follows.

“the Member State which permits transport operations to be carried out in its territory by vehicles or vehicle combinations with dimensions deviating from those laid down in Annex I also permits motor vehicles, trailers and semitrailers which comply with the dimensions laid down in Annex I to be used in such combinations as to achieve at least the loading length authorized in that Member State, so that every operator may benefit from equal condition of competition (modular concept).”

A modular combination is with other words a vehicle combination that principally consists of vehicle units defined in Annex I of the directive. An additional unit, converter dolly, that converts a semitrailer to a full trailer is also necessary. See Figure 1. These vehicle units are coupled together in combinations in order to achieve a total loading length that is a multiple of the module lengths 7,82 m and 13,6 m. These modules are implicitly defined in the directive. The lengths are the envelopes of the lengths of the loading modules. The short module 7,82 m, which is a CEN standard for swap bodies, also includes other standardized load units as 7,45 m, 7,15 m and 20 ft. The long module 13,6 m, which is the European semitrailer length, includes the 40 ft ISO container. The commission declared in December 2006 that also the 45 ft ISO container may be used nationally and in modular combinations if national legislation gives the permission, although its length exceeds 13,6 m with roughly 11 cm.

Figure 1– Vehicle units to combine into modular combinations

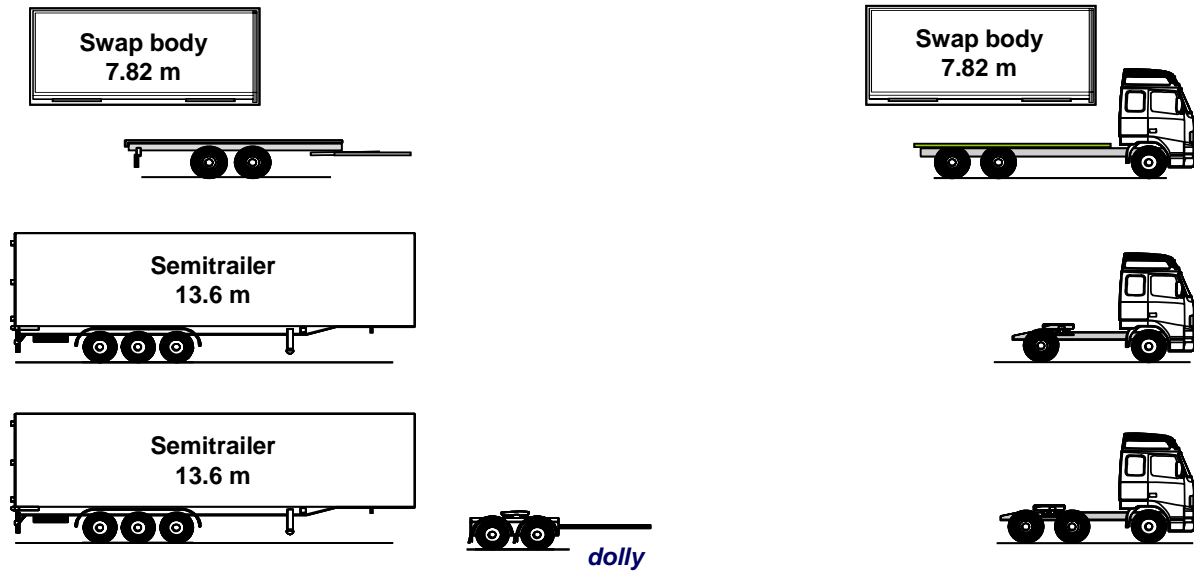

The modular concept is thus a question of length, in particular loading length. Weight is a secondary issue. Modular combinations are flexible and may consist of a varying number of modular units, coupled in different order.

Both Finland and Sweden chose to allow three modular combination types, each carrying one short module and one long module. This gives a required total length of 25,25 m. Both countries allow a GCW of 60 t, which they also did previously. The GCW is not part of the modular concept.

Long vehicle combinations are not intended to be driven on all roads. Classification of the roads in some form is therefore a part of the modular concept. See Figure 2. The intention is to allow modular combinations mainly on primary roads. Before going into secondary roads, they can easily be decoupled into shorter conventional combinations. Also rail roads and waterways should be integrated into the road class system.

Figure 2 – Classification of roads

Road Class 1

(Primary roads)

Road Class 2

(Secondary roads)

Road Class 3

(City streets)

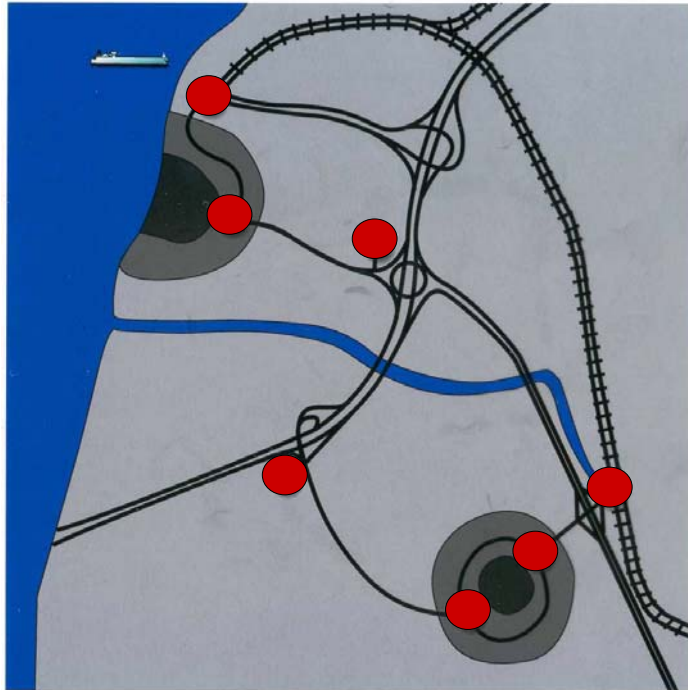

2.3 Advantages with the modular concept

Back in the 1980's, every country had its own regulations on weight and dimension. Consequently, nearly all superstructures, semitrailers and trailers were tailor-made. It could take a year to prepare a chassis and make it ready to go to work. Different countries had different philosophies on axle load, gross weight, wheelbase, loading length, overhang, number of axles etc. The number of variants was huge. The first directive on weight and dimension started a harmonization process.

The international competition became gradually more and more intense. Various solutions that increased the loading volume were developed. As a result, many vehicles became outdated too early. The first directive was updated several times with short intervals. Regulation-driven length changes reduced the residual value of existing vehicles. Also vehicle manufacturers and body builders suffered from these irregularities. This system was particularly disastrous for combined transports and the railroad, as the life of railway wagons is long. It was thus difficult for the railroad to plan the investments. One advantage with the modular concept is that the single loading modules remain the same. Increased vehicle length just means adding one more module.

One obvious advantage with the modular concept is that it reduces the fuel consumption and therefore the emission of CO₂, NO_x and other harmful gases. Longer modular vehicle combinations increase the capacity by volume and also by weight if the GCW is increased. In Sweden where the authorized GCW is 60 t, research has shown that the emission of CO₂ was reduced by 15-20 % per tonkm for modular combinations compared with conventional combinations in general cargo transports. Theoretically the benefit is larger, but the average gross weight of the modular combinations is not 60 t, rather below 50 t. There is a clear and increasing trend towards high cube goods. Typically 90-100 % of the volume and 50-60% of

the weight is utilized in long haul operations. This gives a big advantage for longer modular combinations. Two 25,25 m long modular combinations can replace three conventional combinations, i.e. each modular combination can carry 50 % more volume. The reduction of the emission of CO₂ etc. with respect to volume would thus be larger than with respect to weight. Therefore, the modular concept has no doubt a very large positive environmental impact. See [1],[2],[3].

Another obvious advantage with the modular concept is that they occupy less road space to transport the same amount of goods. This contributes significantly to reduce the congestion, which is a major problem on large parts of the European road network. The following estimate shows to what extent road space is saved by replacing conventional European combinations with modular combinations.

If modular combinations with one long and one short loading module are used, two of these combinations can replace three conventional combinations, two tractor-semitrailer combinations and one truck-trailer combination. It is assumed that each vehicle combination needs a safety distance of 70 m. Table 3 shows the result of the comparison.

Table 3 – Road-space comparison

Combination type	Total road space (m)	Number of palletes	Road space per palette (m)	Relative road space
2 tractor-semitrailer and 1 truck-trailer	262	104	2,52	1,00
2 modular combinations	191	104	1,83	0,73

It appears that more than one fourth of the road space may be saved if these types of modular combinations are used. With longer modular combinations the saving will obviously be larger.

The modular concept is not able to solve the internal problems of the railroad, such as different type of current, different voltage, different signal systems, different track width etc. It facilitates however for intermodal transports on rail road by providing a good interface between road traffic and railroad traffic. This interface is the loading modules.

There have been concerns that long vehicle combinations are less safe than shorter ones. It is however rather the other way around. This will be shown in the following.

Modular vehicle combinations typically wear the roads less than current European combinations. This will also be analyzed in the following.

Modular vehicle combinations have been used in Finland and Sweden since 1997. No problems have been identified. On the contrary, it works well. Some of the experiences are reported in [1],[3].

Since the whole Swedish primary road network (BK1 roads) is open for modular combinations, there is not so much decoupling and coupling that takes place except in intermodal transports. The idea of the modular concept is however used a great deal for transports between Sweden and continental Europe both by Swedish and foreign hauliers. One example is a Swedish forwarding agency with their own fleet of trucks. They have warehouses in the south of Sweden and in France. Outside of Sweden 18,75 m long truck-trailer combinations and 16,5 m long tractor-semitrailer combinations are used. When

arriving in Sweden, these combinations are transformed to 25,25 m long modular combinations. This is done in various ways. On some tractor-semitrailer combinations, a centre-axle trailer is added. Others are decoupled and the semitrailer is put on a converter dolly that is coupled to a rigid truck. There are also tractor-semitrailer combinations that are converted to B-doubles by adding B-semitrailers. Additional 7,82 m loading modules from the warehouse are then loaded on the B-semitrailers. The unloading/loading tour in Sweden may be 1200-1500 km. By using these possibilities to convert the vehicle combinations, the loading capacity for every vehicle increases with 50 %.

3 Stability performance measure of vehicle combinations

Stability in this context refers to oscillatory stability. Various metrics are defined in the international standard ISO 14791 [4]. The most commonly used, and the most relevant in this case, is the Rearward Amplification. It is the relationship between the maximum movements of the first and the last vehicle units during some kind of manoeuvre. It is usually measured in terms of yaw velocity or lateral acceleration gain. Most often these gains are similar. There are however cases in which the use of lateral acceleration gain is very misleading as a stability criterion. Since yaw velocity is a global variable, it is more reliable. The rearward amplification increases when the velocity increases.

In addition, for some types of vehicle combinations it is relevant to use the yaw damping of the lightest damped mode during free oscillations as a stability criterion. The damping always becomes lower for increased speed. The yaw damping rate describes how quickly the amplitudes of the oscillations are attenuated. For some vehicle combinations there may be a speed at which the damping equals zero. If the vehicle speed exceeds the zero damping speed the vehicle becomes unstable, i.e. the oscillations continue with an increasing amplitude without any steer input.

The rearward amplification, RA, may be determined in different manoeuvres. The result depends on the type of manoeuvre. In the following, the Single Lane Change (SLC) method was used. In this manoeuvre the vehicle is steered in such a way that the front axle of the towing vehicle is following a path that corresponds to one full period of sinusoidal input of lateral acceleration. The rearward amplification is defined as the ratio between the maximum peak values of yaw velocity of the last trailer and the motor vehicle. The frequency of the input is varied in order to find the maximum rearward amplification. In the following the vehicle is driven at a constant velocity of 80 km/h. Figure 3 shows an example of the input path and its corresponding lateral acceleration input and Figure 4 shows an example of yaw velocity response from this excitation.

Figure 3 – Example of path-following lane change

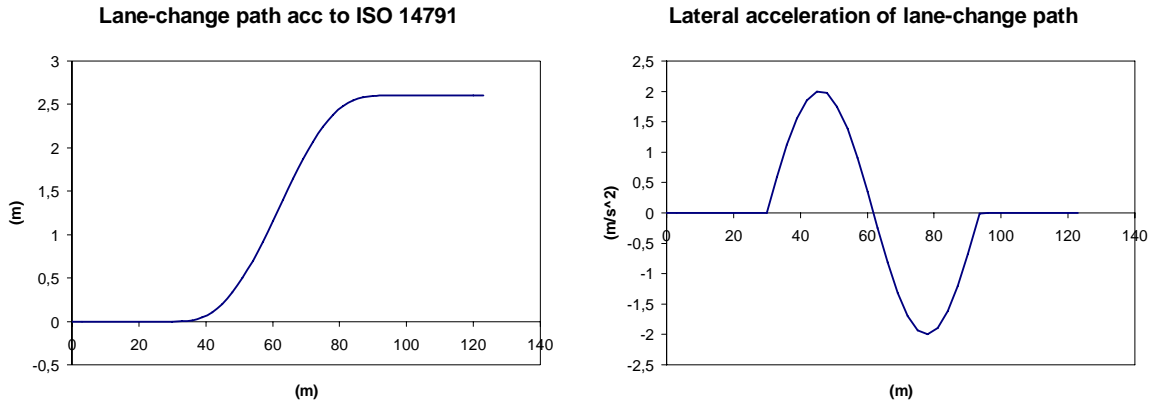

The yaw damping is determined from the free oscillations of the vehicle combination. These are excited by actuating the steering wheel with a pulse and then hold it still. By determining the logarithmic decrement, which is a measure of the rate of decay of free oscillations, the damping ratio may be determined. The procedure is described in [4]. If the damping ratio is 1, the combination is critically damped and there are no free oscillations. With the damping ratio equal to zero, the combination is completely undamped. A negative damping ratio implies that oscillations are self excited.

Figure 4 – Yaw velocity response in a lane change

VCMC6. Truck 6x4 and dolly and semitrailer, forward coupling freq= 0.35 SLC

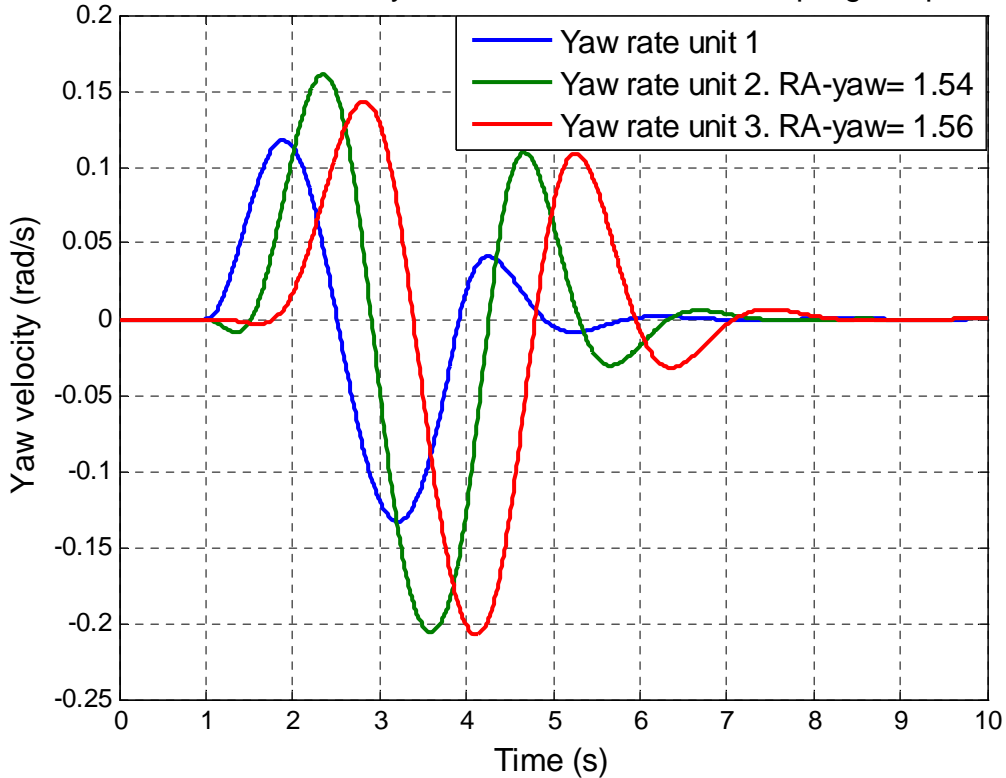

4 Swept path performance measure of vehicle combinations

When the vehicle is negotiating a turn at low speed, it always requires more space than when running straight ahead. This is because the rear wheels, if not steered, do not follow the paths of the front wheels. There is a certain inboard offtracking that depends on the vehicle configuration. Also when all wheels follow the same tracks, the vehicle requires more space than the vehicle width, because there is a part of the vehicle that sweeps inside the wheel tracks. The maximum width of the swept path in a specified manoeuvre is used as performance measure. The lower the speed is the larger the swept path width, SPW. Both when entering and exiting the manoeuvre the rear of the vehicle travels outside the path of the front outside corner (outboard offtracking). This is called tail swing. The tail swing is normally small, but when the trailer wheels are steered it may be significant.

The swept path width depends on, apart from the type of combination, the type of turn that the vehicle is negotiating. Various manoeuvres are currently used. One is a 360-degree turn on a certain outer radius. This method gives an indication of the ability of the vehicle combination to negotiate roundabouts. Directive 96/53 EC uses this method and requires a maximum swept path width of 7,2 m on a 12,5 m outer radius. This does however not apply to modular combinations. For modular vehicle combinations, the Swedish and Finnish regulations require a maximum swept path width of 10,5 m on the same radius. There are also other regulations where larger radii are used.

Another manoeuvre is a 90-degree turn with a small outer radius. The swept path width in this turn governs how tight a corner the vehicle combination can negotiate. The Australian Performance Based Standards use this method with an outer radius of 12,5 m. The swept path width must not exceed 7,4 m for access to the whole road network and must be less than 8,7 m for access to major roads. This manoeuvre can be thought of as the minimum width of road required by the vehicle combination. There is also a Swedish registration requirement that states that vehicles shall be able to negotiate a 90-degree street corner where the road width is 8,5 m.

Lastly a 180-degree turn is another possibility. It indicates the ability to turn back in a roundabout.

The most relevant test manoeuvre for real traffic seems to be the 90-degree turn on a 12,5 m outer radius.

The different manoeuvres are summarized in Figure 5.

Figure 5 – Turning manoeuvres

BO-Kraftkreis, $R=12,5/ 360^\circ$

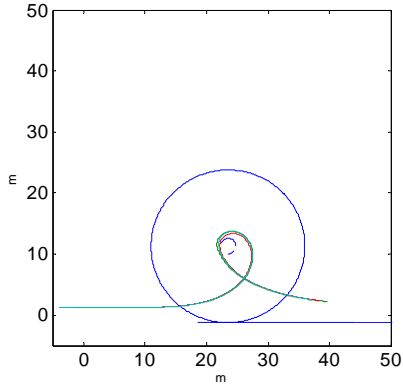

U-turn, $R=12,5/ 180^\circ$

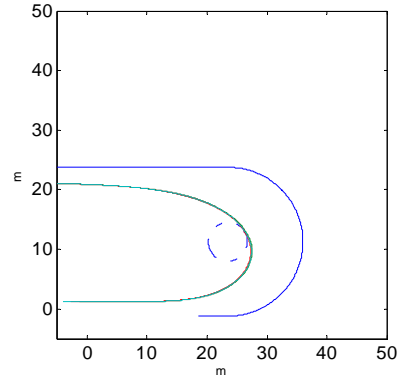

Medium roundabout, $R=20/ 360^\circ$

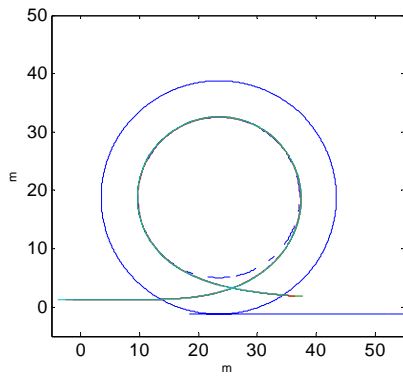

Road intersection, $R=12,5/ 90^\circ$

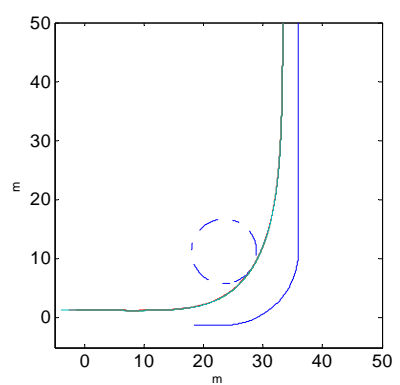
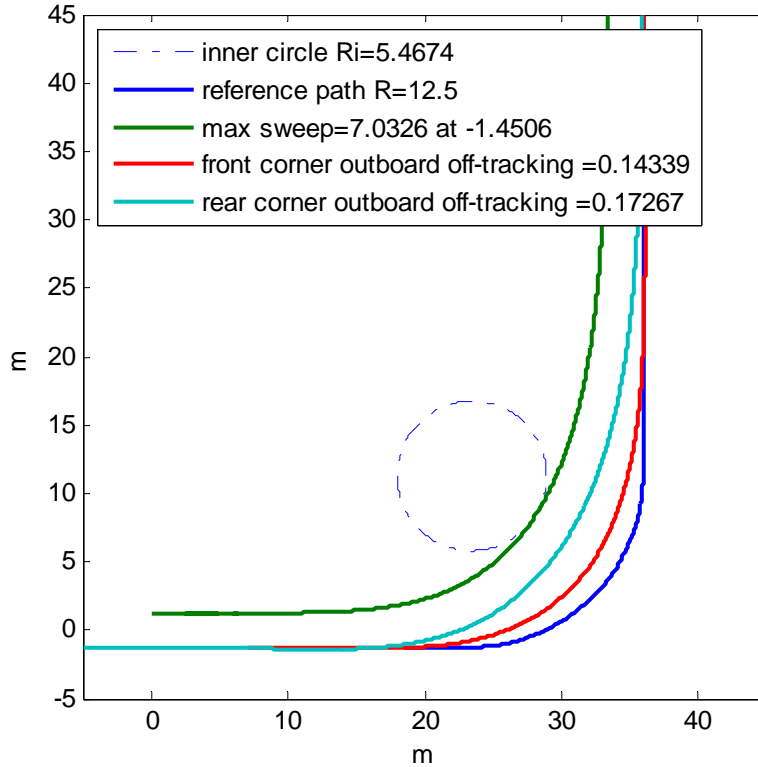

Figure 6 shows the path of the front outer corner of the motor vehicle and the trajectories of the front and rear corners of the last trailer and the trajectory of the point on the last trailer that has the largest swept path width in a 90 degree turn.

Figure 6 – Trajectories in a 90-degree turn

VCMC6. Truck 6x4 and dolly and semitrailer, forward coupling. Max off-tracking of last unit.



5 Road wear performance measure of vehicle combinations

The road wear mechanism cannot be described accurately in a simple way. Firstly there are different failure mechanisms of relevance depending on the type road. Secondly various vehicle parameters, such as suspension design, tyre type, tyre pressure, axle distance, influence the road wear. There is however a widely used “rule of thumb” to estimate the road wear, the so called fourth power law. Even if this calculation does not give quantitatively accurate results in all circumstances, it is nevertheless justifiable to use it in order to estimate the relative road wear of various generic vehicle combination types.

“The fourth power law” calculates the number (N) of equivalent standard axle loads (ESAL) for the vehicle combination.

$$N = \sum (P_i / P_0)^n$$

where,

P_i = actual axle load

P_0 = 10 t

n = 4

By normalizing N with $\sum P_i$, vehicle combinations with different GCW may be compared.

6 Mathematical vehicle model

Each unit in the vehicle combination models consists of a rigid body. They are connected to each other with stiff springs. The springs are stiff enough not to influence the behaviour of the vehicle combination. Each body has longitudinal, lateral and yaw degrees of freedom. Roll has small significance in this context and was therefore left out. The model is non-linear with respect to geometry and tyre forces. The tyres are modelled as Magic Formula tyres. By changing various coefficients, the tyre characteristics may be modified. Figure 7 shows examples of lateral force characteristics of the trailer tyres. The input to the vehicle model is the road-wheel steer angle. A driver model steers the vehicle along a prescribed path. All wheels can be steered proportionally to the steer angle or to the articulation angles.

This vehicle model was used in the following to evaluate stability and offtracking.

Figure 7—Examples of tyre characteristics of trailer tyres

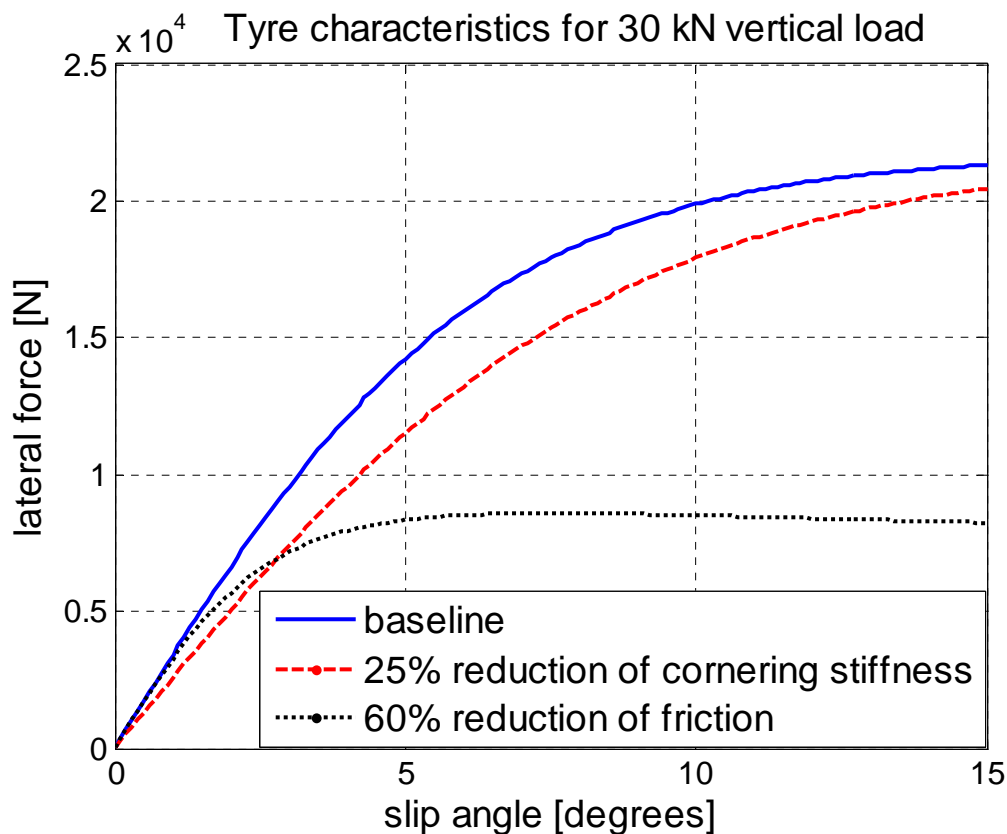

7 The modular concept as applied in the Nordic countries

Since 1997 Finland and Sweden allow the use of three types of vehicle combinations that are 25,25 m long. They are all based on one 7,82 m module and one 13,6 m module. There are no formal performance requirements on stability. It is regarded as being assured by the choice of allowed types of vehicle combinations. There is a performance-based requirement on swept path width, described in clause 4. The vehicle combinations are however deemed

to comply with the requirement, if the distance between the front end of the motor vehicle and the rearmost axle of the last trailer does not exceed 22,5 m and the wheelbase of the semitrailers does not exceed 8,15 m.

The performance of these vehicle combination types will be compared with the performance of currently used, European vehicle combination types. In all cases the load is evenly distributed. The principal of the modular concept is to use existing vehicle units. Therefore the modular combinations are coupled with the same units as the European combinations.

7.1 Vehicle specifications

In order to give a correct comparison, the motor vehicles in all vehicle combinations are equipped with identical front tyres and identical rear tyres and all trailers have identical tyres. The rear axles of the motor vehicles have dual tyres, all other axles have single tyres. Also the inertial properties are important for the results. Masses are easily determined, but moments of inertia have to be estimated. This is done with the formula below for each vehicle unit.

$$\text{Yaw moment of inertia} = x \cdot \text{payload} + I_t$$

where x and I_t are obtained from the table below.

Vehicle unit	x	I_t
Tractor	0	30000
Rigid	4,6	80000
Centre-axle trailer	5,6	12000
One-axle dolly	0	1500
Two-axle dolly	0	3000
Semitrailer	12,5	70000
Link semitrailer	4,6	130000
Long link semitrailer	12,5	170000
Full trailer without dolly	4,6	12000

7.1.1 European vehicle combinations for international traffic

These vehicle combinations are based on directive 96/53 EC. They all have a GCW of 40 t. Axle loads, mass of each vehicle unit and payload are shown below figures of respective vehicle combinations.

#1 Tractor and semitrailer

This is the most commonly used vehicle combination. The maximum distance from the front of the tractor to the fifth wheel is 4,5 m and from the fifth wheel to the end of the semitrailer, it is 12,0 m, which gives a total length of 16,5 m. The maximum front overhang of the semitrailer is 2,04 m, which gives a length of 13,6 m for a semitrailer with a flat front. The wheelbase of the tractor is pretty much determined by these dimensions. The wheelbase of the semitrailer is determined by SPW requirements. A wheelbase of up to 8,115 m (kingpin–centre axle) is however deemed to comply (for the vehicle width 2,60m), according to directive 97/27, with the turning circle requirements in the directive 96/53. A long semitrailer wheelbase gives higher kingpin load and more load on driven axles. This is advantageous in

modular combinations in order to get better traction. The tractor wheelbase 3,6m and the semitrailer wheelbase 8,115m were therefore chosen. The axle distances of the semitrailer is 1,31 m. The distance from the front axle to the fifth wheel is 3,14 m. The loads on the trailer bogie axles are equalized.

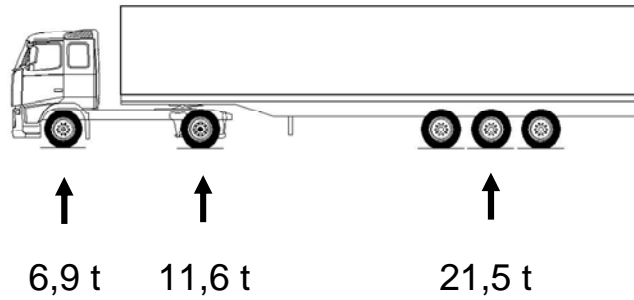

Vehicle unit	1	2
Mass (kg)	8000	32000
Payload (kg)	-	25000

As appears in the figure, the tractor is overloaded and the driving-axle load is slightly above the limit. The mass centre of the load has to be moved rearwards to make the vehicle combination legal. The only possibility to be legal with even load distribution is to use a semitrailer with shorter wheelbase.

#1b Tractor and semitrailer

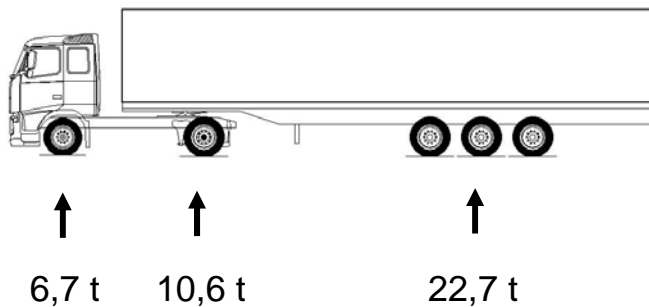

Vehicle unit	1	2
Mass (kg)	8000	32000
Payload (kg)	-	25000

With the semitrailer wheelbase 7,55m, which is among the shortest in use, there will be a certain margin for uneven load distribution. This margin is however too small. In practise, the driving axle of this type of vehicle combinations is therefore often overloaded. In fact, this vehicle combination is unsuitable with current driving axle load and GVW limits. It is configured for both higher driving axle load and higher GVW. Consequently, a three-axle tractor is necessary.

#2 Tractor and semitrailer

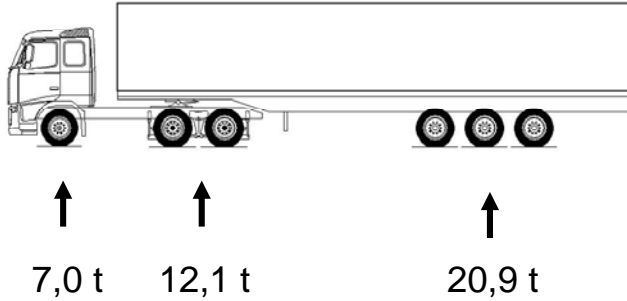

Vehicle unit	1	2
Mass (kg)	9000	31000
Payload (kg)	-	24000

The wheelbase of the tractor, i.e. the distance from the front axle to the first axle of the bogie, is 3,0m and the distance between the bogie axles is 1,37m. Each bogie axle carries 50 % of the bogie load. The distance to the fifth wheel is 3,14m. The semitrailer is identical with the one in combination #1, i.e. the wheelbase is 8,115m. This combination has a good margin for uneven load distribution. The penalty is of course lower payload for the same GCW. These tractor and semitrailer are also used in all the following combinations having tractor and semitrailer.

#3 Truck and centre-axle trailer

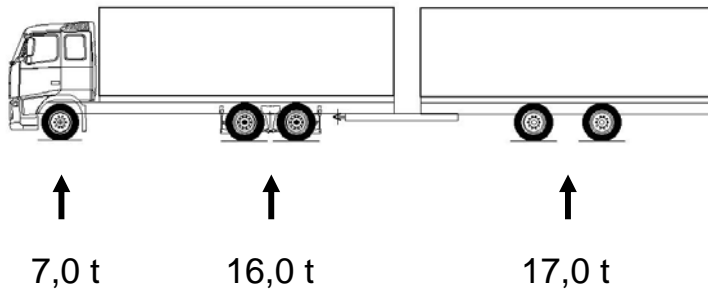

Vehicle unit	1	2
Mass (kg)	23000	17000
Payload (kg)	13000	13000

This is the second type of European vehicle combinations. It has a permitted loading length of 15,65m, which gives the length 7,82 m of each loading unit. The maximum total length is 18,75m. The axle distance of the trailer bogie is 1,8 m and the axle loads are equalized. The bogie of the motor vehicle is identical with the one used on the three-axle tractor. In the standard case the trailer is loaded in such a way that the hitch load is zero. The coupling distance, A, i.e. the distance between the coupling axis and the rear end of the truck, is 1,5

m, which gives that the distance between the coupling and the rearmost axle is 1,1m. Both the motor vehicle and the trailer are used in the following.

#4 Truck and full trailer

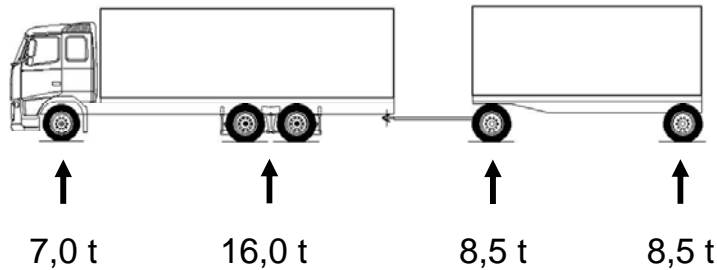

Vehicle unit	1	2	3
Mass (kg)	23000	1500	15500
Payload (kg)	13000	-	11500

There are various configurations of this vehicle combination type. This is a rather typical one. The maximum permitted total length is 18,75m, but the effective loading length is less than for the previous vehicle combination. This one has a 7,82 m loading unit on the truck and a shorter one on the trailer. Because of this, it is not fully compatible with the modular concept. The wheelbase of the trailer is 5,1m. The coupling distance is 0,2 m.

7.1.2 Modular vehicle combinations

The weight is not a part of the modular concept, but in this comparison the modular vehicle combinations have a GCW of 60 t, which is maximum authorized weight in the Nordic countries. Tractor, rigid truck, semitrailer and centre-axle trailer in the modular combinations are identical with those in the European combinations. Axle loads, mass of each vehicle unit and payload are shown below the figures of respective vehicle combinations.

#5 Tractor, semitrailer and centre-axle trailer

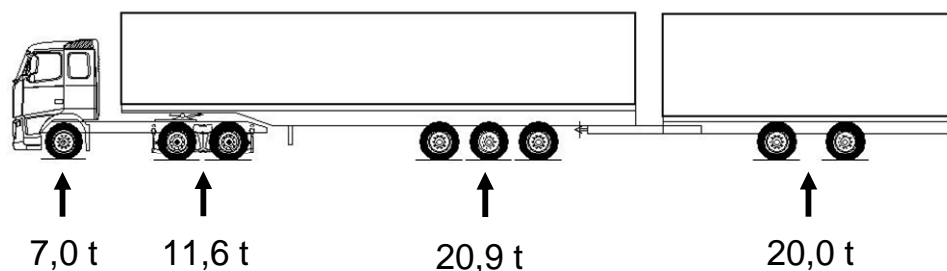

Vehicle unit	1	2	3
Mass (kg)	9000	31000	20000
Payload (kg)	-	24000	16000

This modular vehicle combination consists of a standard tractor–semitrailer combination with a centre-axle trailer at the end. The total length is roughly 25,25 m. The semitrailer has the same load as in the conventional European tractor–semitrailer combination, and the centre-axle trailer is loaded such that a GCW of 60 t is obtained. The centre-axle trailer is loaded so there is no vertical load on the coupling. It is obvious that it is not possible to reach 25 % of the weight on driving axles with evenly distributed load. In order to reach that, the centre of gravity of the payload on the semitrailer has to be shifted forward. A coupling is required at the end of the semitrailer. The distance between the coupling axis and the rear end of the trailer is 1,5 m, i.e. 1,1 m behind the rearmost axle. This position implies that the centre-axle trailer is compatible both with rigid trucks and with semitrailers.

#6 Truck, dolly and semitrailer

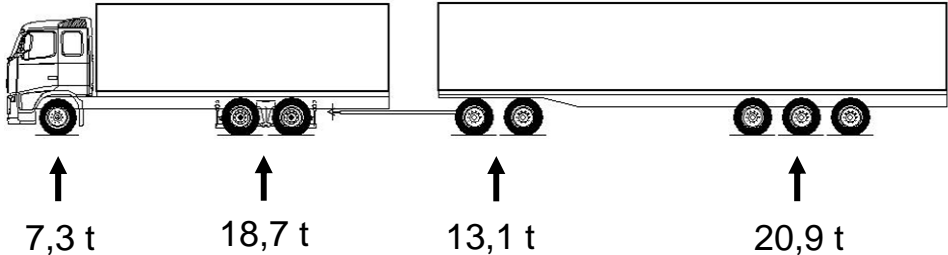

Vehicle unit	1	2	3
Mass (kg)	26000	3000	31000
Payload (kg)	16000	-	24000

The second modular combination, which, conceptually, is a truck—full trailer combination, consists of a standard rigid truck, a converter dolly and a standard semitrailer. The total length is approximately 25,25 m. The distance between the coupling axis and the rear end of the truck is 1,5 m. The truck is therefore suited for hauling centre-axle trailers as well. The semitrailer is evenly loaded as previously, and the truck is loaded up to maximum allowed gross vehicle weight in order to obtain a GCW of 60 t. One advantage with this type of vehicle combination is that the weight carried by driving axles easily exceeds 25 % of the total weight. This is very beneficial for traction on winter roads. This combination has an overall harmonic distribution of the axle loads.

#7 Truck, dolly and semitrailer

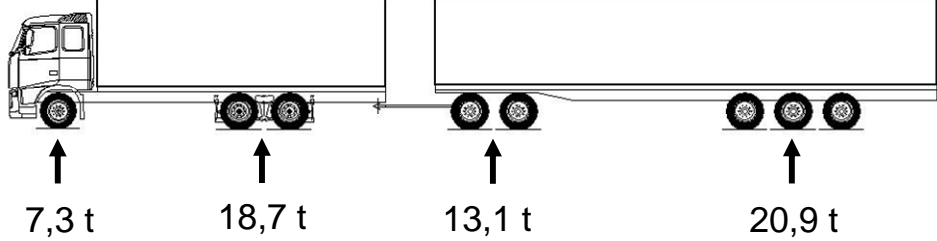

Vehicle unit	1	2	3
--------------	---	---	---

Mass (kg)	26000	3000	31000
Payload (kg)	16000	-	24000

This modular combination is identical with the previous one, except that the coupling distance is short, only 0,2 m. This position is preferred by some hauliers for various reasons. It changes however the behaviour of the vehicle.

#8 B-double, 7,82 + 13,6

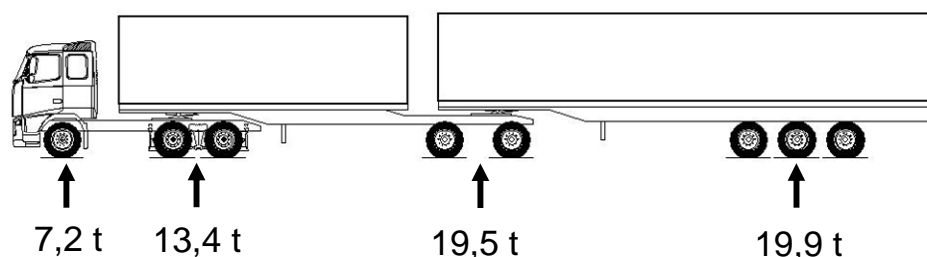

Vehicle unit	1	2	3
Mass (kg)	9000	21500	29500
Payload (kg)	-	15000	22500

This is the third modular vehicle combination carrying one short and one long loading module within 25,25 m total length. It consists of a standard tractor hauling two semitrailers, of which the last one is a standard semitrailer. The first one, called a B-semitrailer, has a fifth wheel at its end, 0,39 m in front of the last axle, on which the second semitrailer is coupled. The wheelbase of this semitrailer is the same as of the last one, i.e. 8,115 m. The axle distance of the B-semitrailer is 1,8 m. The kerb weight of the vehicle combination is higher than for the previous ones. Therefore the payload on each loading unit is reduced in order to get a GCW of 60 t. The axle load on the B-semitrailer is close to maximum authorized load. 25 % of the total weight on driving axles is not quite achieved with even load distribution. The margin for uneven load distribution is small. The loading may therefore be tricky. This combination is however currently the most common B-semitrailer.

#9 B-double, 7,82+13,6

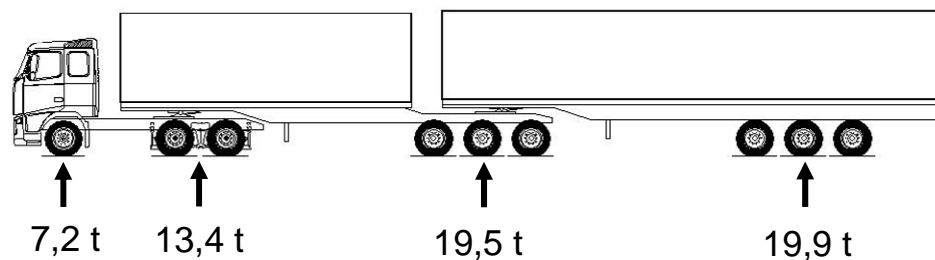

Vehicle unit	1	2	3
Mass (kg)	9000	21500	29500

Payload (kg)	-	15000	22500
--------------	---	-------	-------

This combination is similar to the previous one, except that the B-semitrailer has three axles instead of two. This gives a larger flexibility with respect to load distribution.

7.2 Performance

7.2.1 Stability

The rearward amplification of yaw velocity evaluated in a path-following lane-change manoeuvre, as described in clause 3, is a measure of dynamic stability. For each vehicle combination the frequency of the excitation is varied in order to find the maximum gain. In Figure 8 the rearward amplification is shown for conventional European and currently used modular combinations. The modular truck – dolly – semitrailer combination used in this comparison has a distance of 1,5 m from the coupling axis to the rear end of the truck. The B-double has a B-semitrailer with two axles.

For vehicle combinations with centre-axle trailers, there may be a risk for instability due to low yaw damping. In these cases it is not sufficient to use only the rearward amplification as a metric of dynamic stability, also the yaw damping at various speeds must be considered. This is done in conjunction with studies of the effect of parameter changes in clause 9. Vehicle combinations with no centre-axle trailers have normally sufficient yaw damping.

Figure 8 – Gain comparison between conventional European and modular combinations

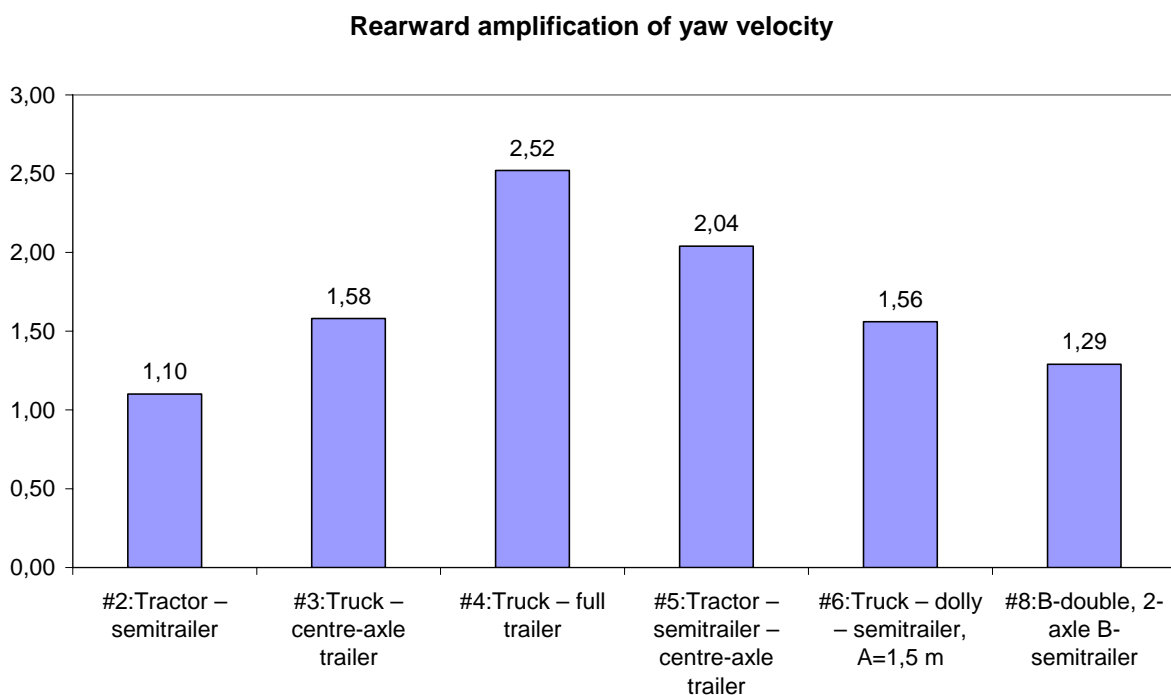

The highest gain is obtained with the European truck—full trailer combination. The tractor—semitrailer—centre-axle trailer gives the second highest amplification. The remaining European and modular combinations are quite good and in the same ball park. The tractor—semitrailer combination with a large trailer wheelbase and no steered axles has very good dynamic stability.

7.2.2 Offtracking

The swept path width (SPW) in certain manoeuvres at very low speed is used as a measure of offtracking, as described in clause 4. Quite often the swept path is estimated from models where the tyre slip is not taken into account. This underestimates the swept path width, especially in turns with small radii.

The offtracking at very low speed was calculated in four different manoeuvres. In Figure 9, the swept path width is shown for the previous vehicle combinations. In one case the bar is missing, which means that it is not possible to negotiate that turn.

It is obvious that the swept path width is smaller for larger turning radii, and also that it increases with the turning angle. Another observation is that, for small turning radii, the difference between shorter and longer vehicle combinations increases dramatically when the turning angle increases. The difference between the tractor-semitrailer and the truck – dolly semitrailer is for example only 1,15 m in a 90-degree turn on a radius of 12,5 m, while the difference in a 360-degree turn is as large as 3,66 m. The difference in absolute terms is much smaller in turns on the radius 20 m, as is shown in Figure 10.

Figure 9—Offtracking comparison for various manoeuvres

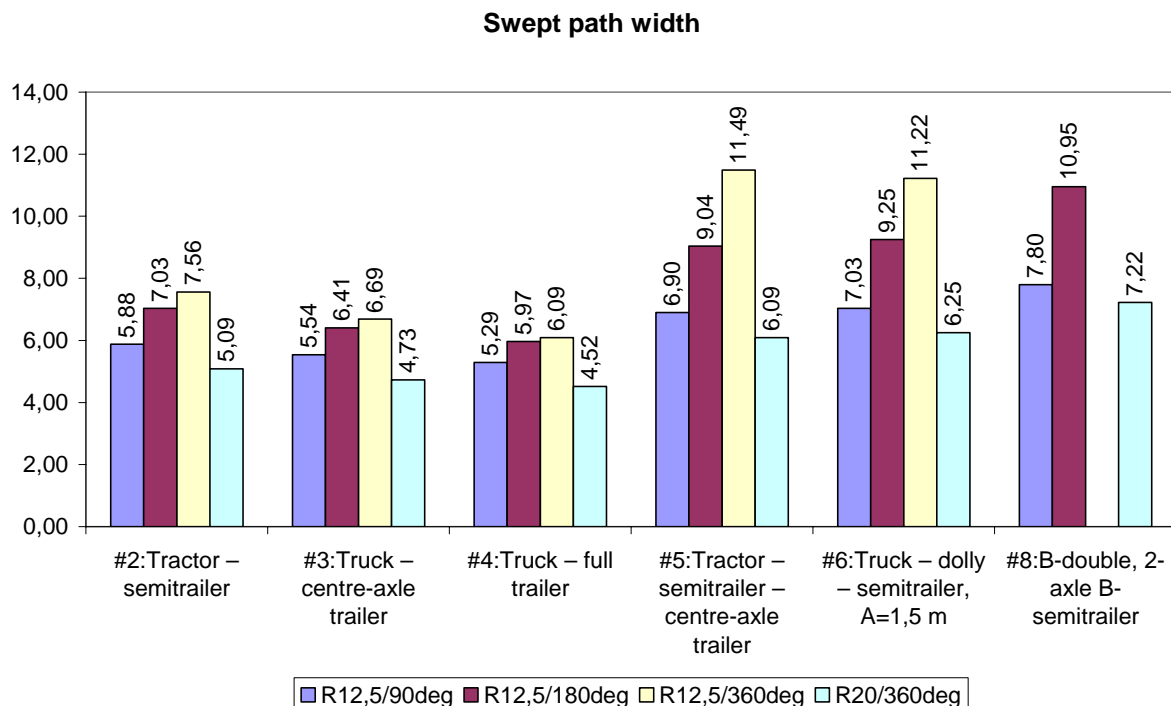
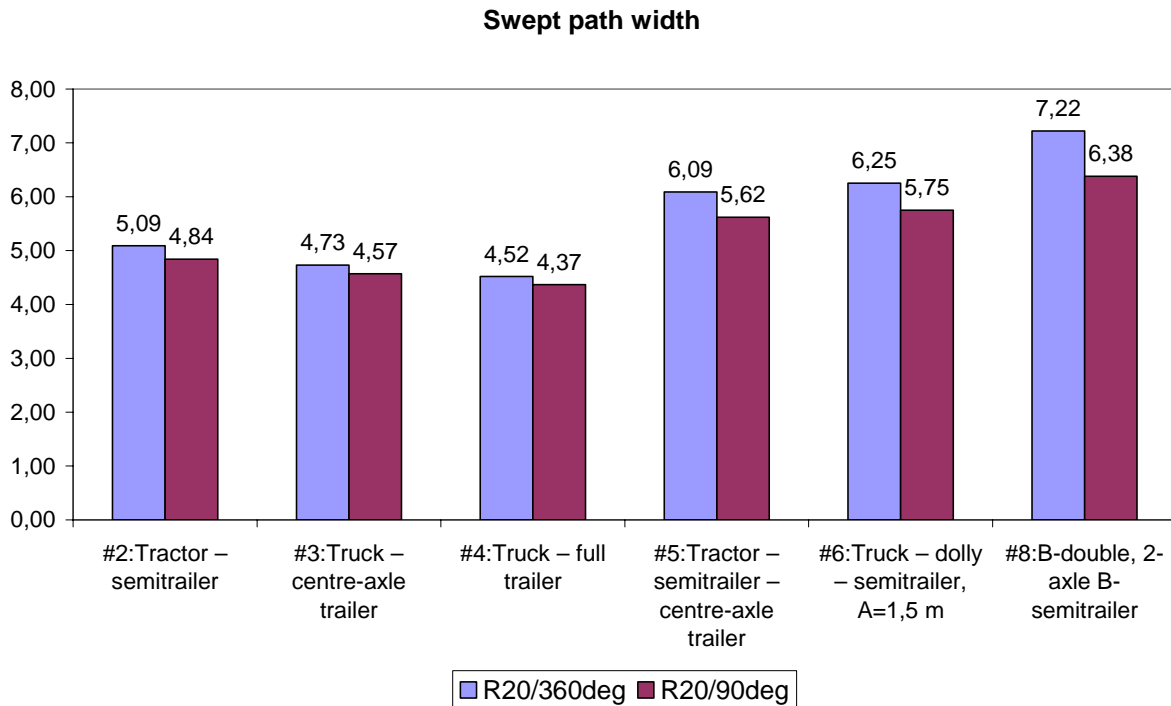

Figure 10 – Offtracking comparison for turning radius 20 m



7.2.3 Road wear

The number of equivalent standard axle loads using the axle loads and the "fourth-power law" is calculated. In order to determine how many ESAL's that are necessary to transport 1000 t for each vehicle combination, the numbers are normalized with the GCW and multiplied by 1000. The result is shown in Figure 11 for the same combinations as previously and for tractor – semitrailer combinations, both with two-axle tractor(#1) and three-axle tractor(#2).

It appears that the modular combinations cause less road wear than the five-axle tractor – semitrailer combination. The reason is primarily that the maximum and average axle loads are smaller in the modular combinations. The six-axle tractor – semitrailer combination, on the other hand, causes much less road wear.

Figure 11 – Road wear comparison

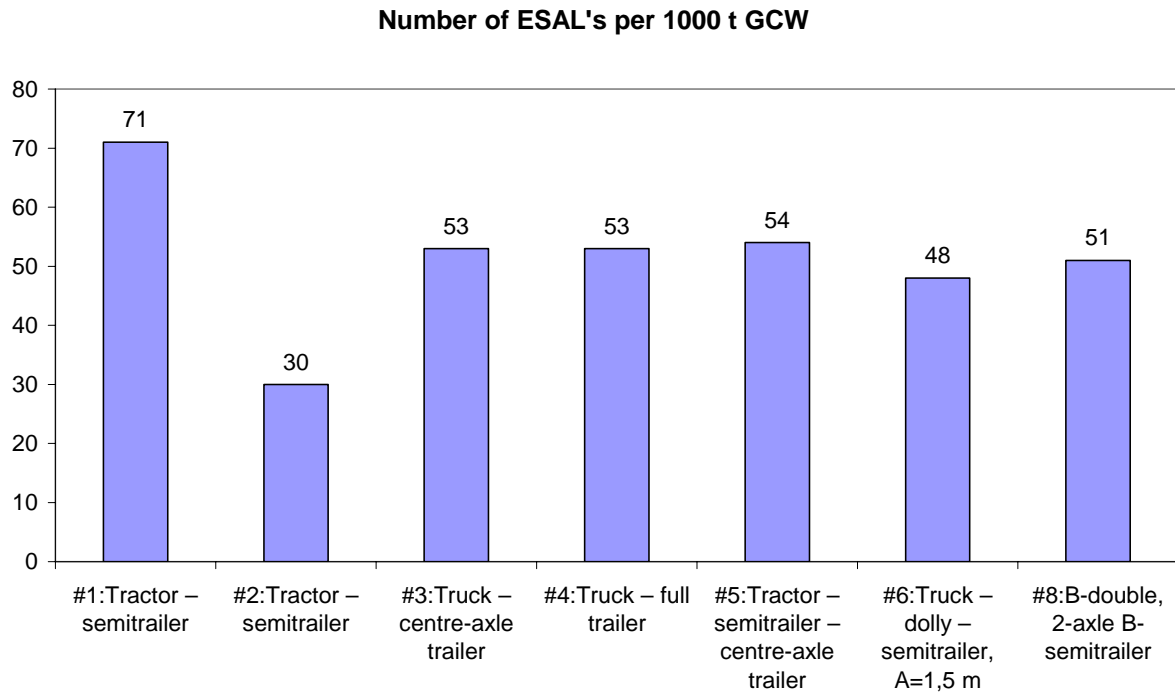

8 Prospective modular vehicle combinations

In current modular vehicle combinations one short (7,82 m) and one long (13,6 m) modular unit are coupled together in various ways. This gives a total length of 25,25 m. In many cases, on appointed road networks, it would be appropriate, cost effective and environmental friendly to use longer modular vehicle combinations with other combinations of loading modules. Below, possible longer modular vehicle combinations are described, of which at least some are likely to be used in the near future on European roads. They are coupled together with the same vehicle units as above. The load is in all cases evenly distributed. The vehicle combinations are loaded to a GCW of 60 t in order to be comparable with previous modular combinations.

8.1 Vehicle specifications

#10 A-double, 13,6 + 13,6

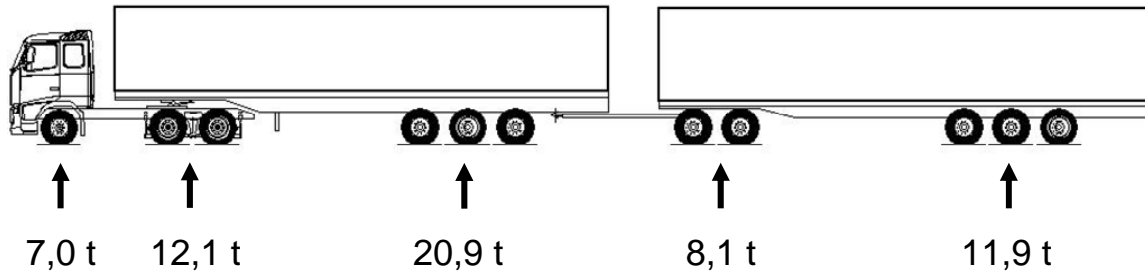

Vehicle unit	1	2	3	4
Mass (kg)	9000	31000	3000	17000
Payload (kg)	-	24000	-	10000

This combination consists of a tractor, two identical standard semitrailers and a converter dolly. It has a total length of 31,5 m. The distance from the pintle hitch coupling to the end of the semitrailer is 1,5 m. The first semitrailer is fully laden and the rest of the payload is on the second semitrailer. It is not possible to achieve 25 % of the total weight on driving axles with even load distribution.

#11 Double centre-axle trailer

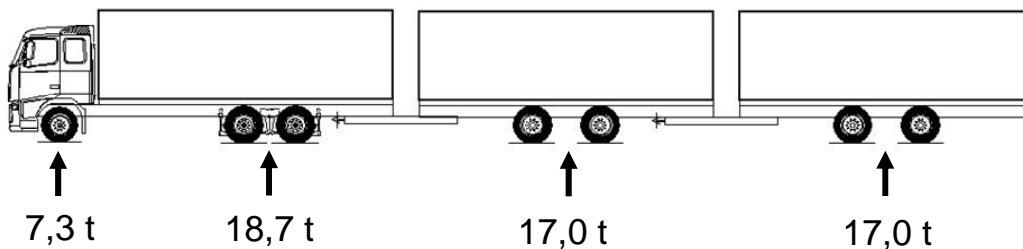

Vehicle unit	1	2	3
Mass (kg)	26000	17000	17000
Payload (kg)	16000	13000	13000

This combination consists of a rigid truck and two standard centre-axle trailers. It carries three 7,82 m loading modules. The coupling distances are all 1,5 m, and there is no vertical load on the coupling. A large part of the load is carried by driving axles, which gives good traction. The total length of the combination is 27,3 m.

#12 Double centre-axle trailer

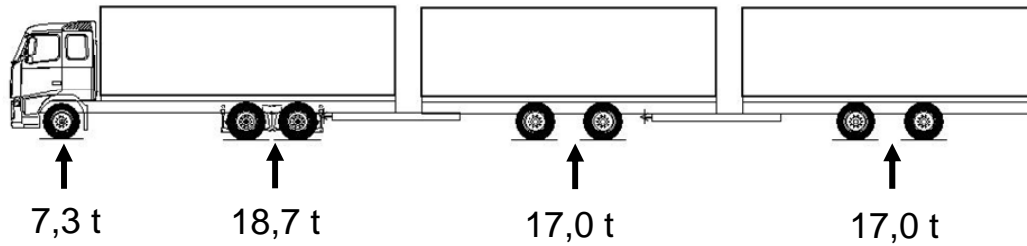

Vehicle unit	1	2	3
Mass (kg)	26000	17000	17000
Payload (kg)	16000	13000	13000

The only difference between this vehicle combination and the previous one is the coupling distance, which is 1,9 m on all units in this case.

#14 B-double, 13,6 + 13,6

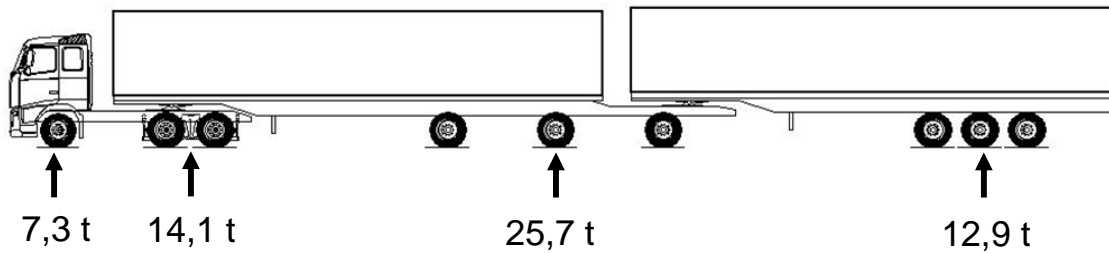

Vehicle unit	1	2	3
Mass (kg)	9000	32500	18500
Payload (kg)	-	24000	11500

This is an optional way to transport two long load modules. It gives a total length of 30,9 m. The last semitrailer is a standard one, but the first one is a long B-semitrailer with a large bogie spread. The axle distance is 3 m. The wheelbase of the B-semitrailer is 10,7 m. The distance to the fifth wheel on the semitrailer is 0,7 m behind the last axle. To avoid excessive wheel scrubbing it may be necessary to steer the axles of the B-semitrailer at low speeds. The B-semitrailer cannot be coupled to a tractor and driven in ordinary European international traffic without reducing its length by sliding the axles forward.

#14b B-double, 13,6 + 13,6

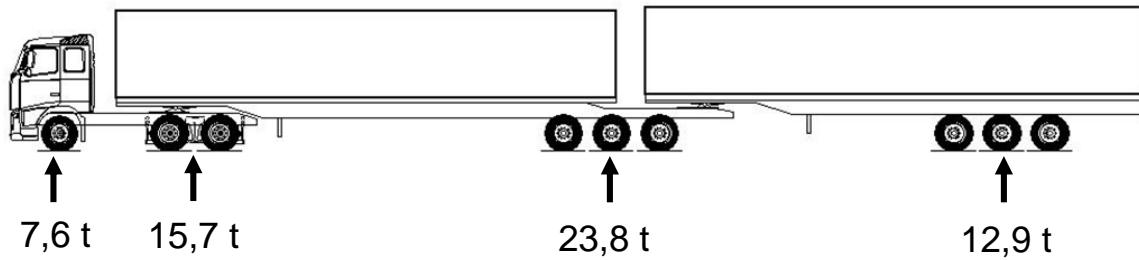

Vehicle unit	1	2	3
Mass (kg)	9000	32500	18500
Payload (kg)	-	24000	11500

This is a similar combination as the previous one but with a standard triple bogie on the B-semitrailer. This gives almost no margin for uneven load distribution on the triple. It also gives a very long wheelbase and an unfavourable position of the fifth wheel.

#15 Truck and B-double

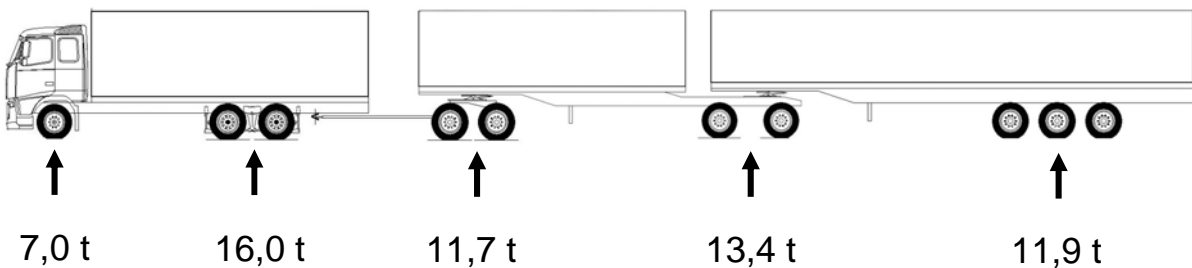

Vehicle unit	1	2	3	4
Mass (kg)	23000	3000	17000	17000
Payload (kg)	13000	-	10500	10000

With a rigid truck, a converter dolly and the two trailers in a conventional B-double it is possible to transport two 7,82 m modules and one 13,6 m module. The total length of this modular combination is 33,8 m.

#16 B-triple

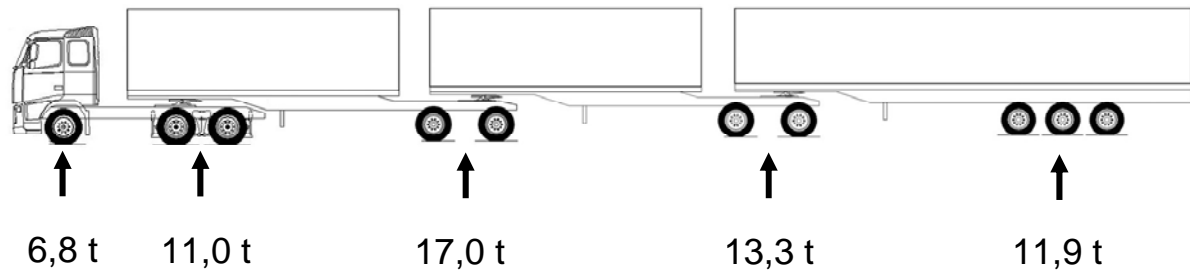

Vehicle unit	1	2	3	4
Mass (kg)	9000	17500	16500	17000
Payload (kg)	-	11000	10000	10000

Two short and one long loading modules can also be transported with a combination consisting of tractor, two B-semitrailers and one standard semitrailer. This gives a total length of 33,8 m.

8.2 Performance

8.2.1 Stability

The rearward gain to the last trailer in a path-following lane change is shown in Figure 12 for conventional European vehicle combinations and for future modular vehicle combinations. Stability aspects concerned with yaw damping are considered in clause 9.

Figure 12 – Gain comparison between current European and new modular combinations

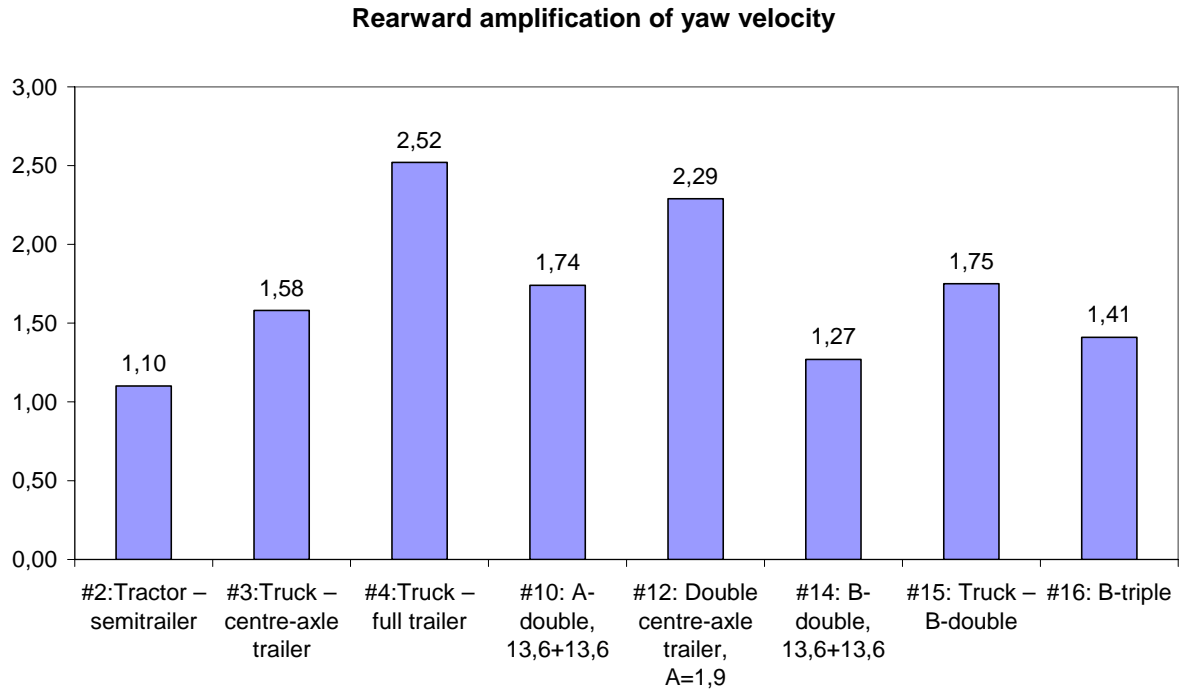

The largest rearward amplification among these prospective vehicle combinations is obtained for the vehicle combination with two centre-axle trailers. It is however still smaller than for the European truck–full trailer combination. All the other longer modular combinations have a moderate rearward amplification, also those with three articulation joints. Normally an increased number of articulation joints aggravates the stability. Other factors, such as combination type and wheelbases, may however have larger influence.

8.2.2 Offtracking

The swept path width was calculated when negotiating the same four manoeuvres as previously. Figure 13 shows the offtracking of all the long modular combinations compared with a typical tractor – semitrailer combination.

Figure 13 – Offtracking comparison between new modular combinations

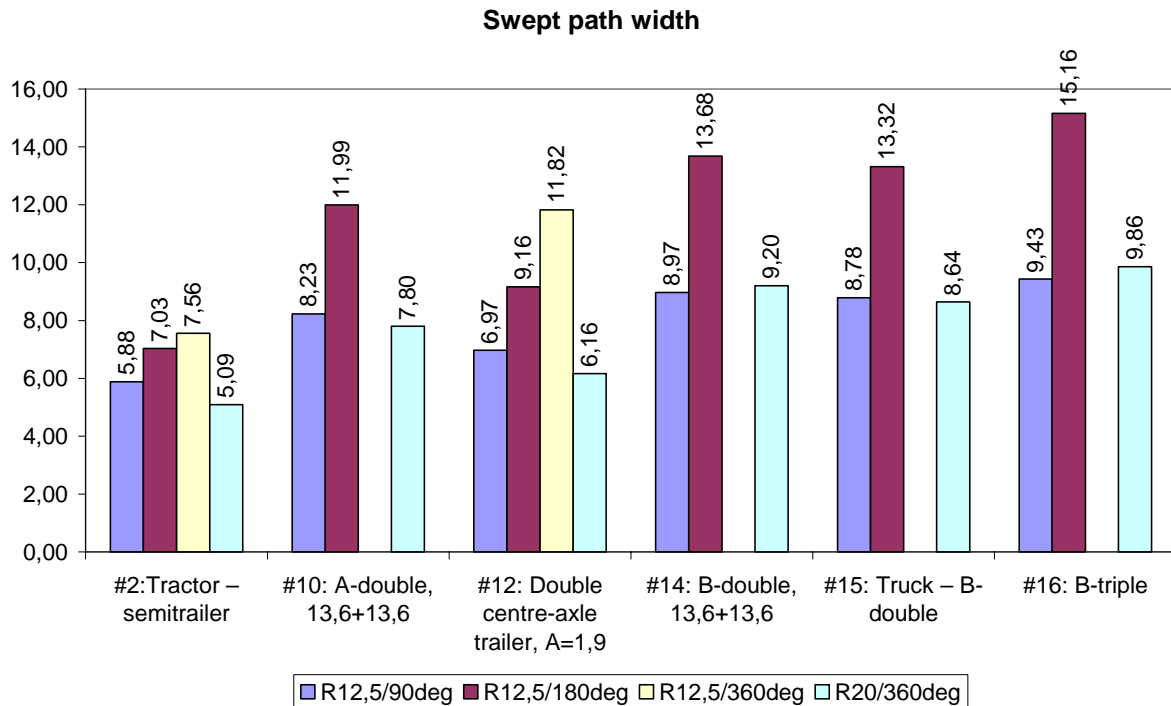

Obviously the difference between the long combinations and the short one is large especially for large turning angles. The difference in 90 degree turns is however much smaller. The combinations with B-coupled semitrailers and the A-double cannot negotiate the 360-degree turn on a 12,5 m radius.

8.2.3 Road wear

As appears in Figure 14, the longer modular vehicle combinations cause substantially less road wear, primarily due to lower axle loads. The double centre-axle trailer combination is however not much better than the five-axle tractor–semitrailer combination (#1) due to fewer axles.

Figure 14 – Road wear comparison between new modular combinations

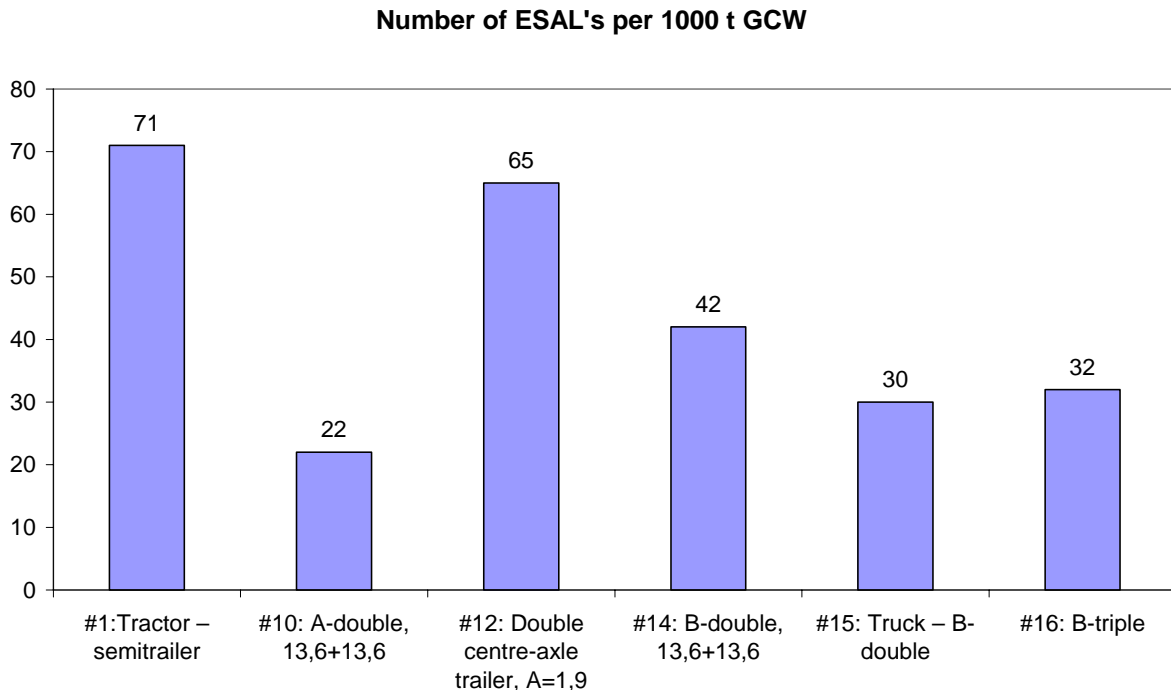

9 Parameter study

Geometry, inertial properties, mass distribution and type of combination affect the performance of the vehicle combinations. It is not feasible, and does not make sense, to investigate all possible combinations of parameter variations systematically. Therefore a few of the most relevant parameters were investigated for representative vehicle combinations. From this general conclusions may be drawn.

9.1 Tractor – semitrailer (#2)

This vehicle combination has normally quite a good dynamic stability. Figure 15 shows the influence of two parameter changes on the rearward amplification. Increased inertia of the trailer has generally a negative influence on the stability. In this case the effect is however marginal. This may depend on that the inertia difference between tractor and trailer is already very large. Steered axles of the trailer have, however, a large impact on the stability, especially if the axles are self steered. The yaw damping of this vehicle combination type is good.

Normally yaw velocity and lateral acceleration responses are similar. Figure 16 illustrates however that the differences in some cases may be huge. The large increase of yaw velocity gain with one self-steered axle is almost not seen in the lateral acceleration gain. This depends on that the location of the measurement point of acceleration is decisive for the result. This is not the case with yaw velocity, which is the same everywhere on a rigid body. Looking at the lateral acceleration response may thus be misleading.

There are two reasons for introducing steered axles, reduced tyre wear and decreased swept path width. The effect on offtracking is shown in Figure 17.

One steered axle naturally reduces the swept path width, but does no miracles. The loss of dynamic stability is larger than the gain of manoeuvrability.

Figure 15 – Gain effect of inertia and steered axles

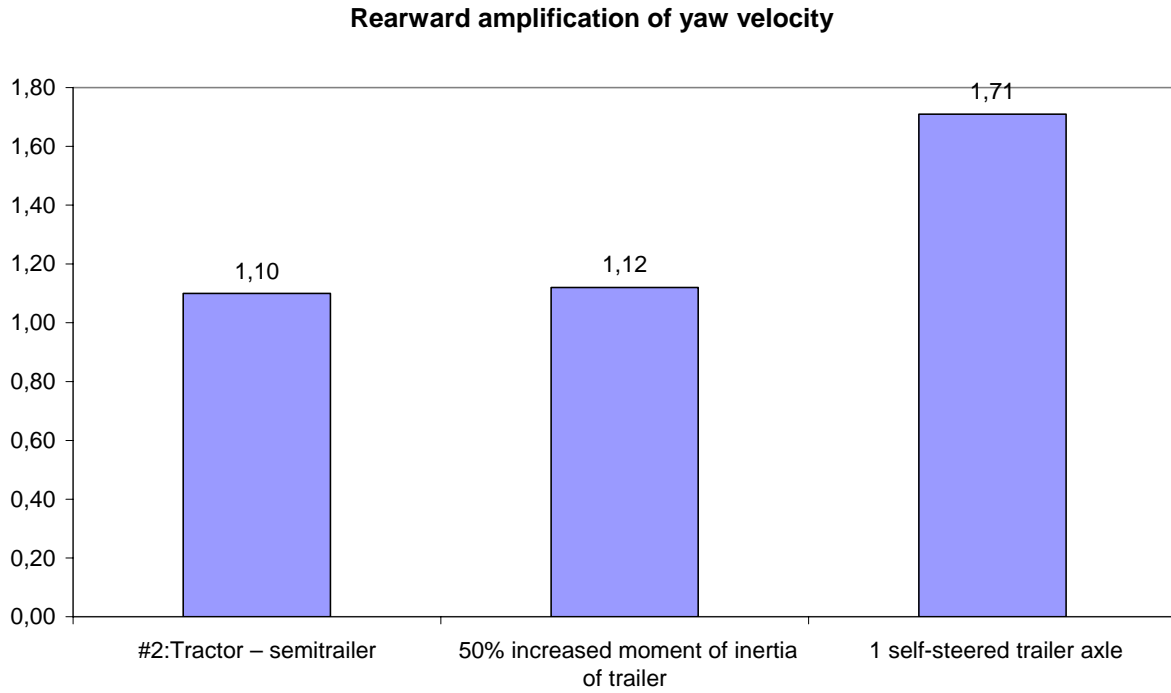

Figure 16 – Yaw velocity vs. lat acc gain with self-steered axle

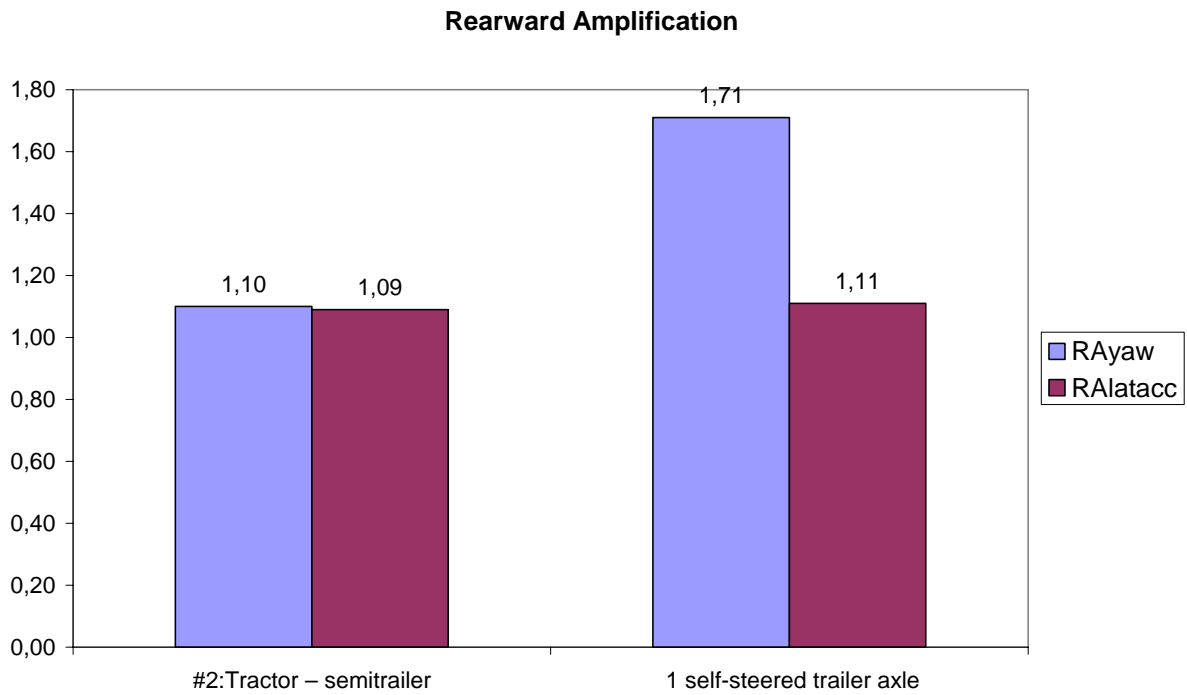
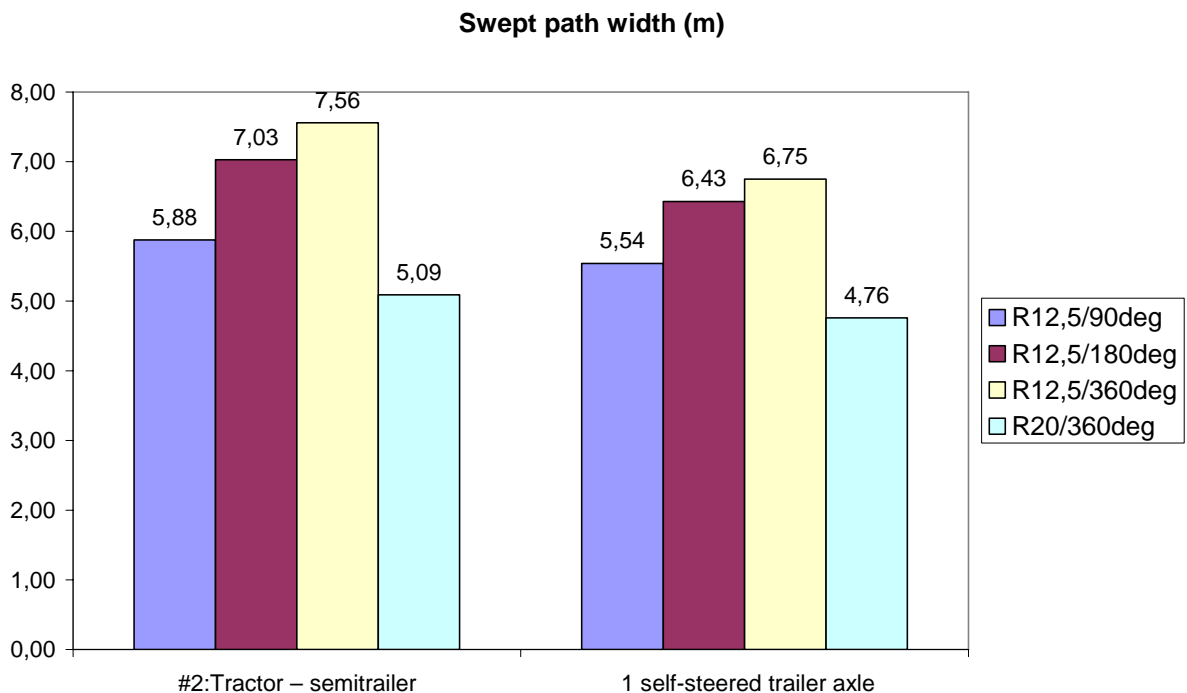

Figure 17 – Effect of steered axles on offtracking



9.2 Truck – centre-axle trailer (#3)

This combination type is sensitive to a large number of parameters; geometrical and inertial. This appears in Figure 18. Both increased moment of inertia of the trailer and increased mass of the trailer give higher rearward amplification. The increased mass also increases the moment of inertia. The positions of the coupling with respect to the rear axles of the truck and the wheelbase of the trailer have a larger influence in this case. In a real vehicle a longer coupling distance implies also a larger wheelbase of the trailer. For lowest rearward amplification the coupling distance and the trailer wheelbase shall be large. Vertical load on the coupling improves the dynamic stability.

Looking at the rearward gain is not always sufficient in order to judge the dynamic stability of a vehicle combination. The yaw damping of a vehicle combination, as described in clause 3, decreases for increasing speeds. If there is a speed at which the damping becomes negative, the oscillations of the combination are self excited and the vehicle combination unstable at speeds above the zero-damping speed. In vehicle combinations with centre-axle trailers, there is a risk for low damping. Figure 19 shows free oscillations of the yaw velocity of the truck—centre-axle trailer described in clause 7.1.1 at a speed of 80 km/h. This vehicle combination is well damped, with a relative damping of 0,30. When the coupling distance is reduced to 0,2 m, accompanied by corresponding reduction of the trailer wheelbase, the damping is reduced to 0,14, as appears from Figure 20, which also shows that moving the load rearwards, so that truck and trailer have the same weight, reduces the damping significantly. The damping becomes only 0,01 at a speed of 80 km/h. If the speed increases to 81 km/h, the damping becomes negative and the combination unstable, i.e. the oscillation amplitudes increase until an accident occurs. Loading the coupling vertically, with the rearward coupling position, increases the damping to 0,08, see Figure 20. At a speed of 89

km/h, the zero-damping speed is reached in this case. Self-excited oscillations when the zero-damping speed is exceeded are shown in Figure 21.

Figure 18 – Effect of various geometrical and inertial changes on the gain

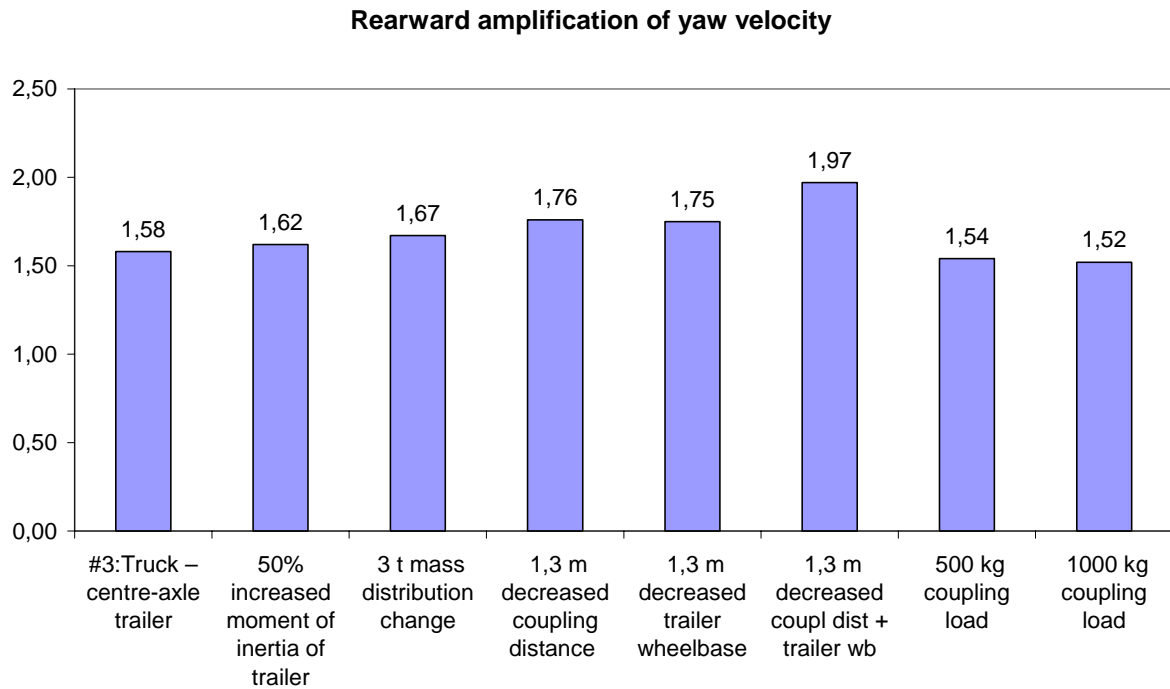

Figure 19—Well-damped yaw velocity response

VCMC3. Truck 6x4 and centre axle trailer freq= 0.3 SSW;
A=1.5m, 80 km/h

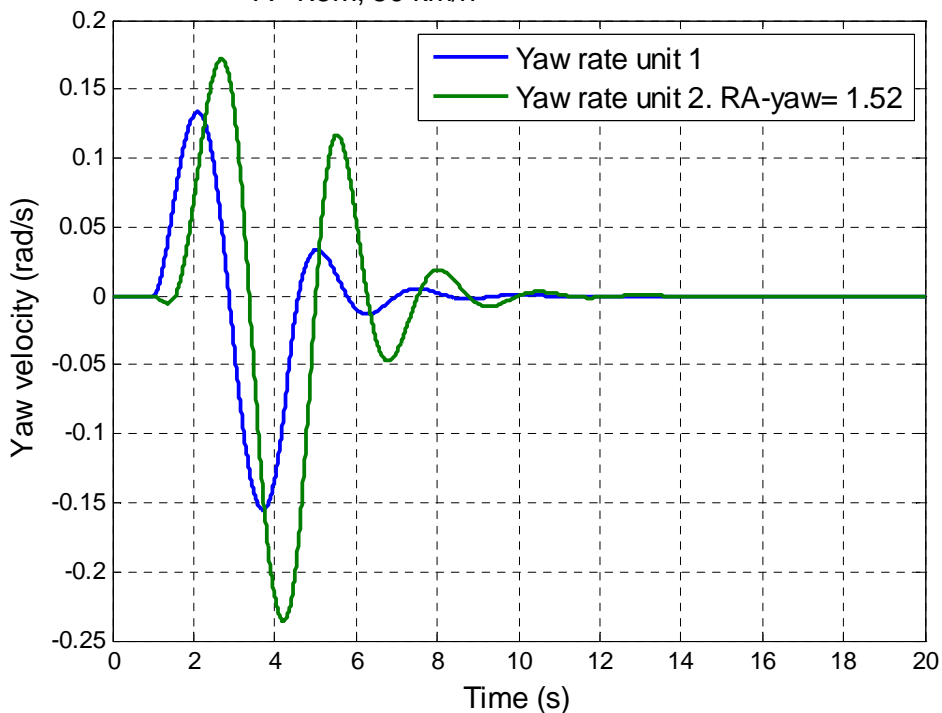

Figure 20—Effect on yaw damping from various changes

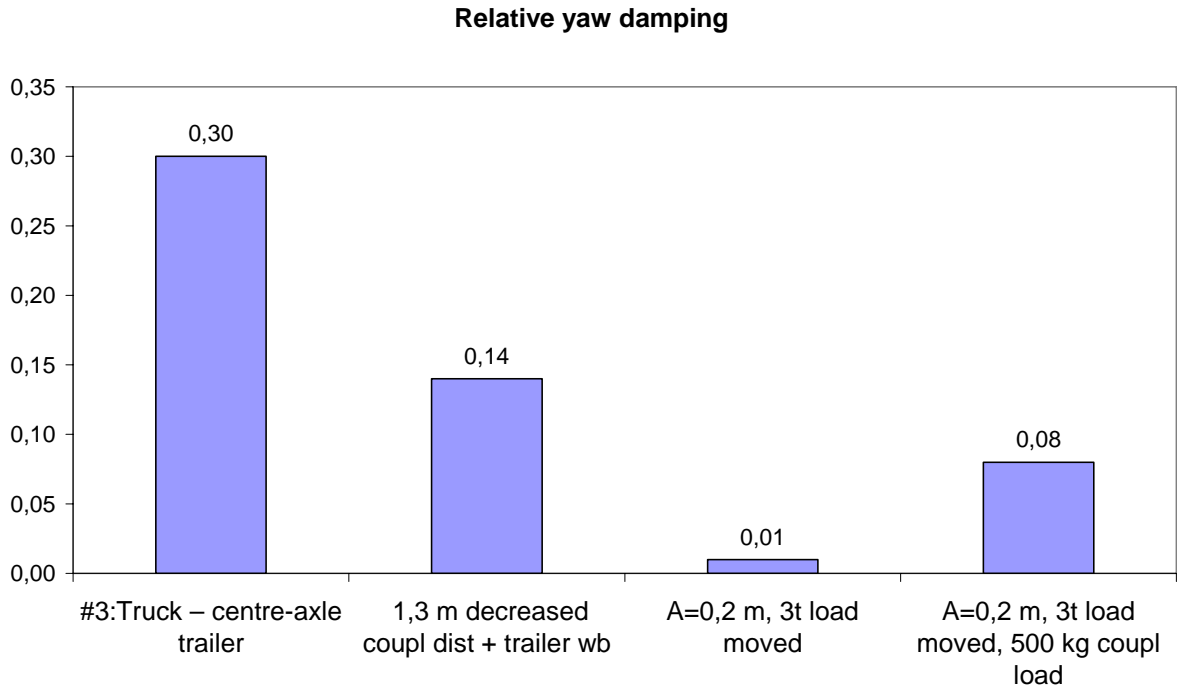

Figure 21—Self-excited yaw velocity response

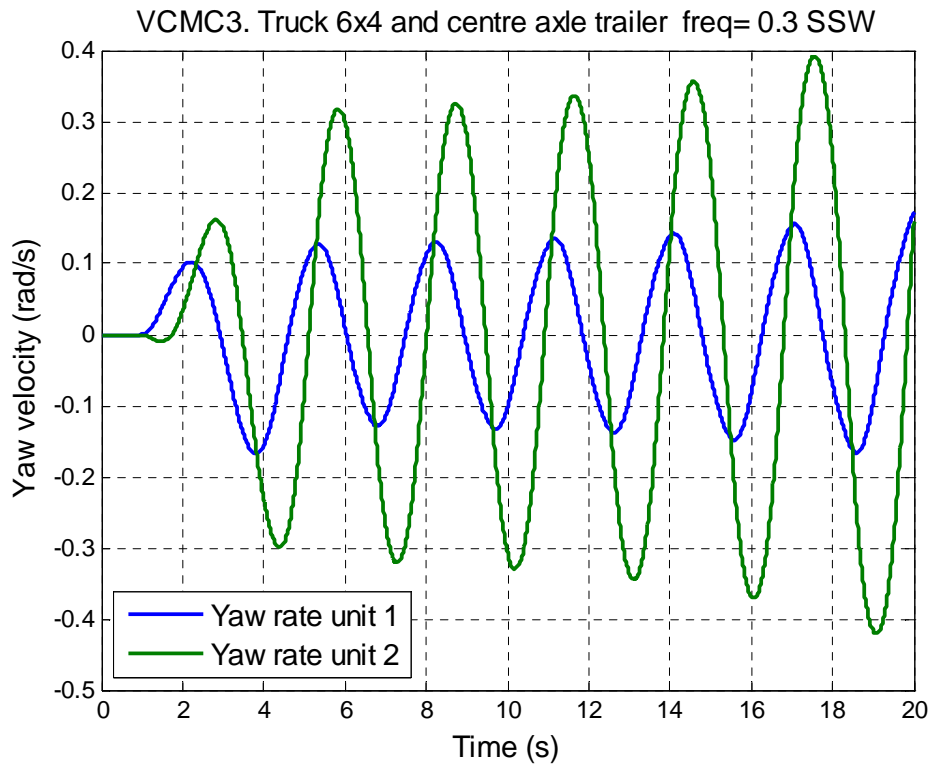
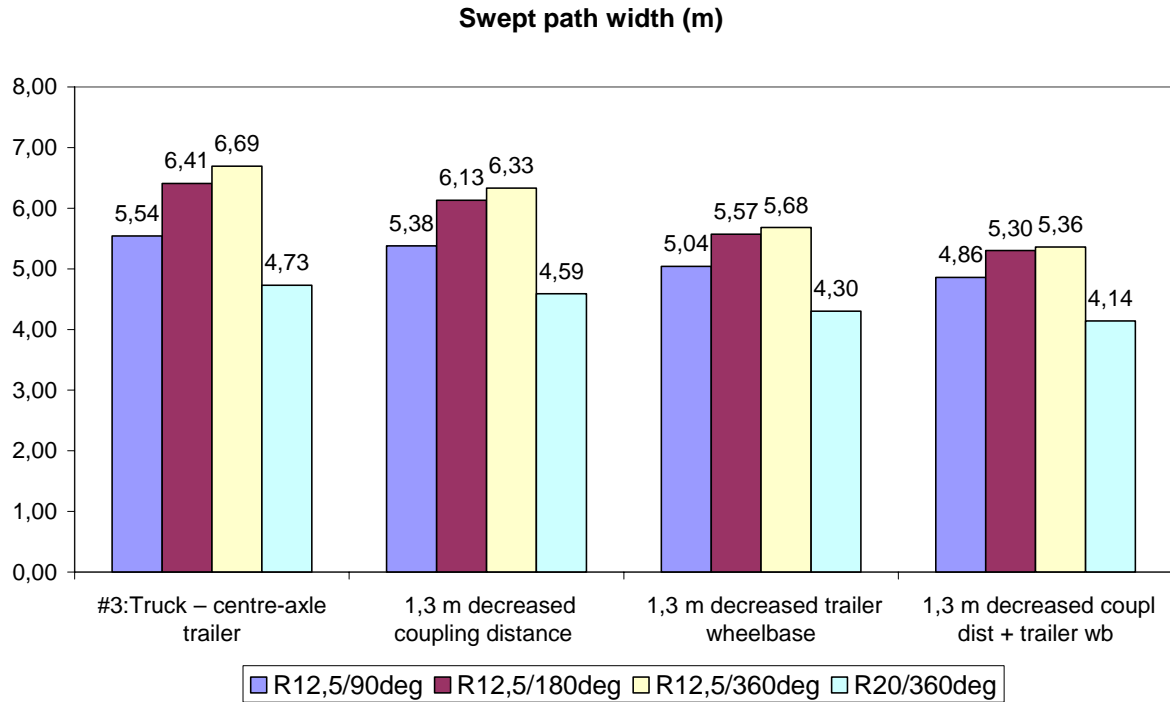

Figure 22 shows the effect on the offtracking properties by the geometrical variations. Both longer coupling distance and trailer wheelbase increase the swept path width.

Figure 22 – Effect on the offtracking from various geometry changes



9.3 Truck – full trailer (#4)

Also for this combination, both moving the mass rearwards from truck to trailer and moving the centre of gravity of the trailer rearwards impair the stability, as appears in Figure 23. Longer drawbar has a positive effect and reduces the rearward amplification. The yaw damping of this type of vehicle combination is sufficient.

Figure 24 shows, on the other hand, that a longer drawbar increases the swept path width.

Figure 23 – Influence on rearward gain

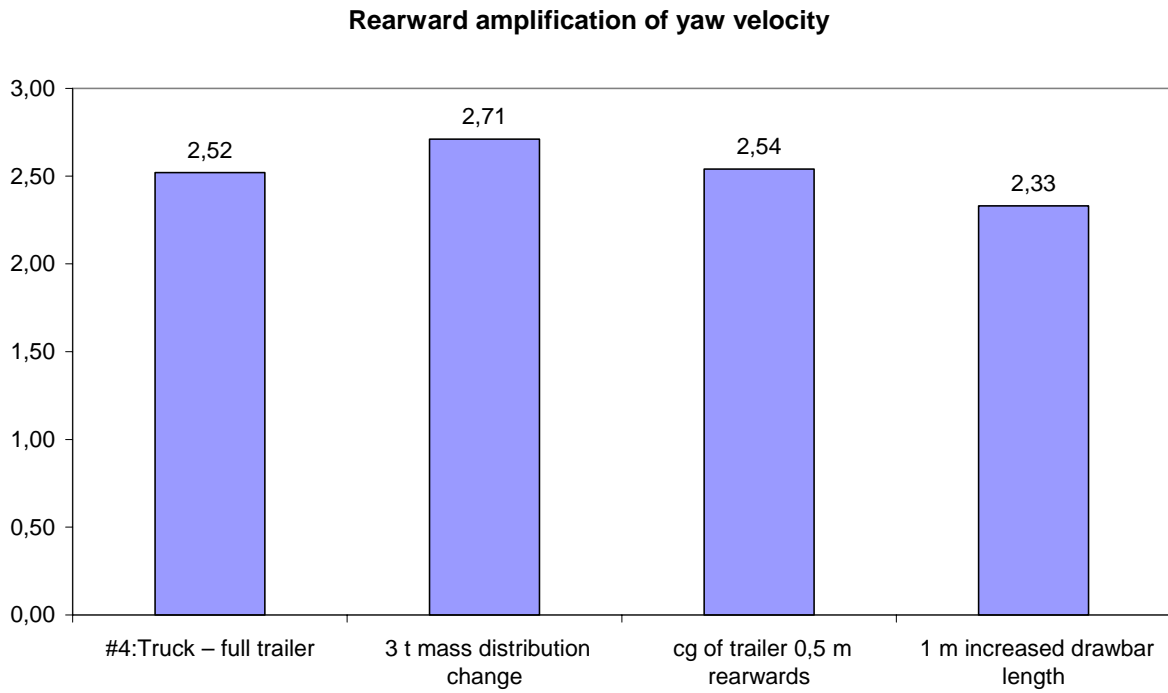
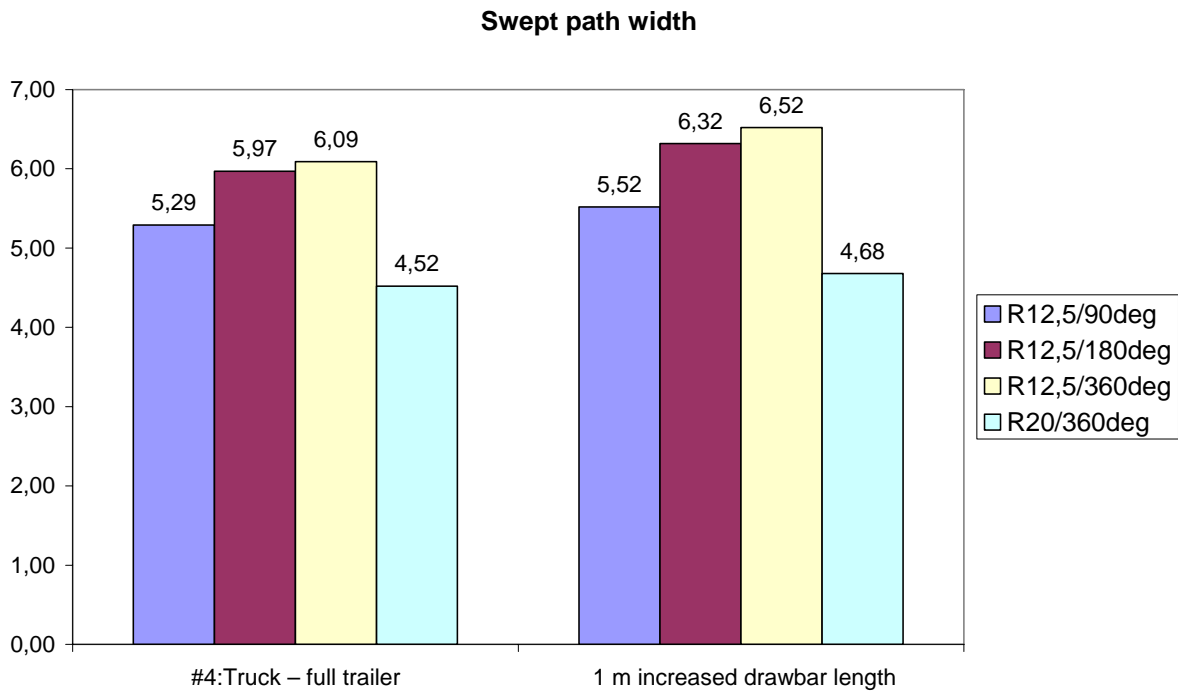

Figure 24 – Influence of drawbar length on offtracking



9.4 Tractor – semitrailer – centre-axle trailer (#5)

This combination is quite sensitive to the position of the coupling. Moving the coupling close to the rear end of the semitrailer increases the rearward gain significantly, see Figure 25. The cornering stiffness of the trailer tyres has also a large effect on the stability.

Figure 25 – Influence on the rearward amplification

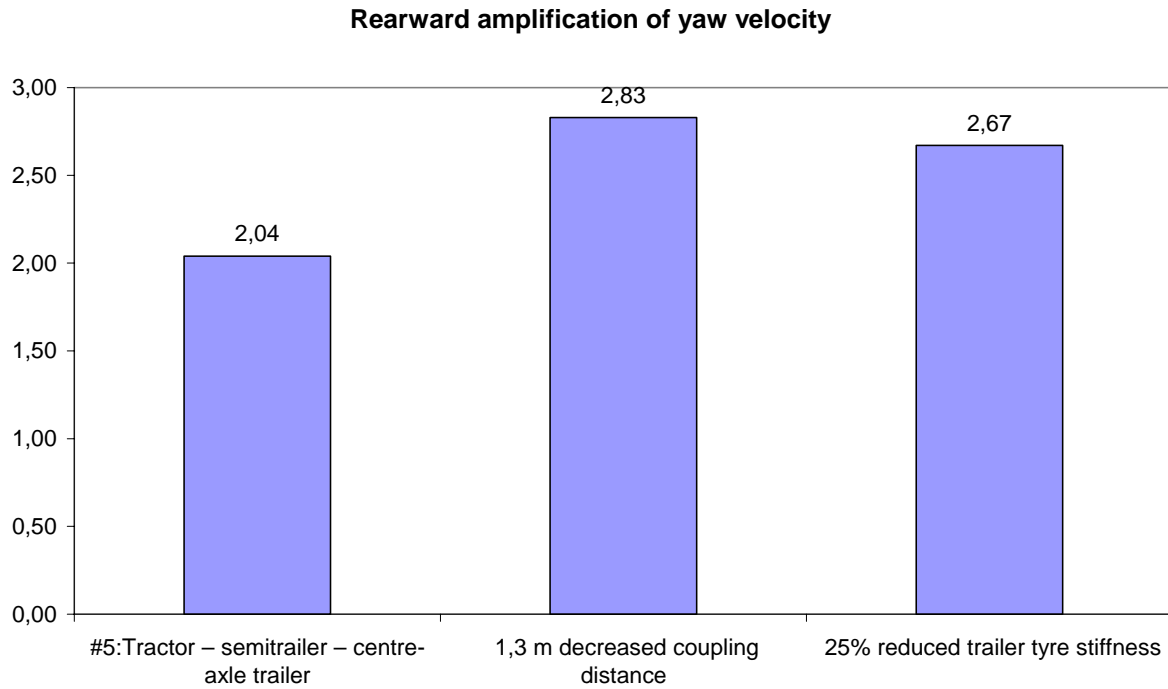

The yaw damping of this vehicle combination is good and causes no problems. With a rearward position of the coupling on the semitrailer, however, the damping is significantly reduced as appears in Figure 26.

As shown in Figure 27, the rearward location of the coupling improves the offtracking of the vehicle.

Figure 26—Effect of coupling distance on yaw damping

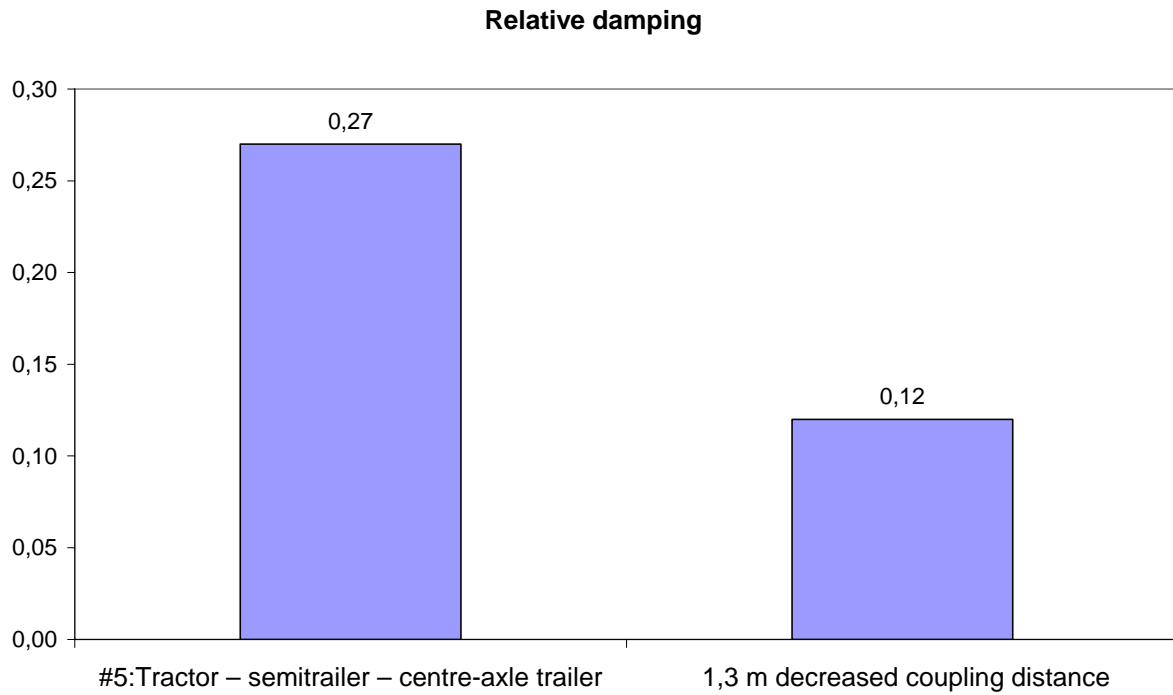
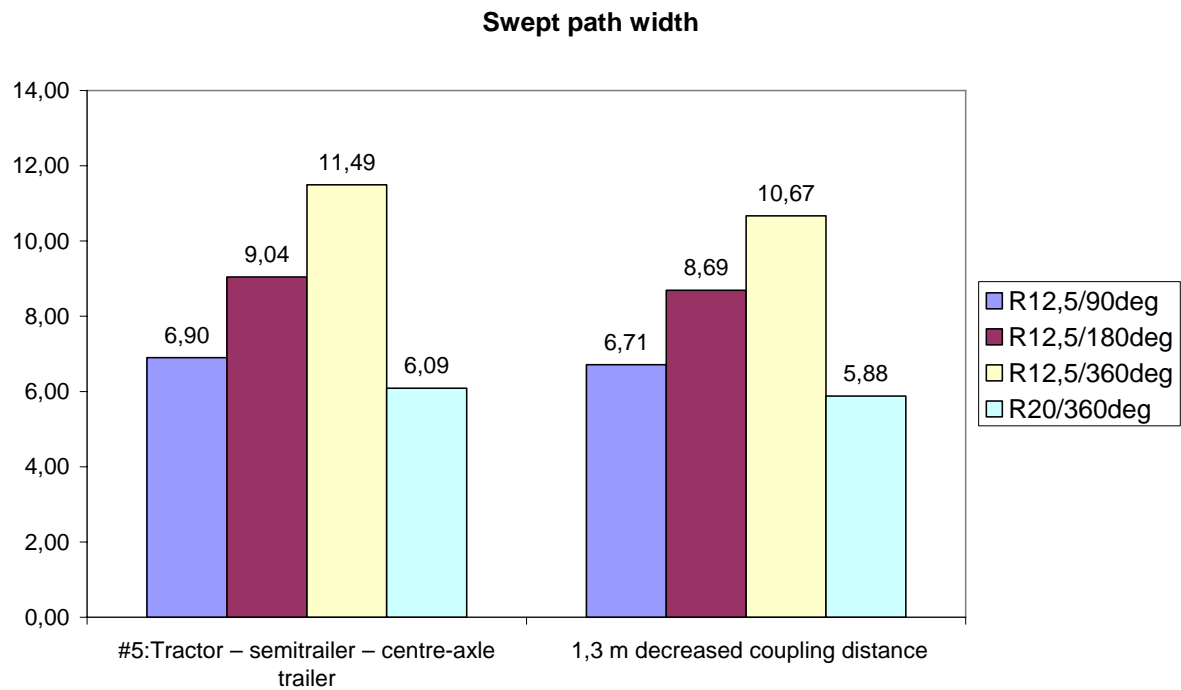

Figure 27 – Offtracking



9.5 Truck – dolly – semitrailer (#6)

The stability of this truck–full trailer combination has good dynamic stability thanks to the long wheelbase of the trailer. It is however affected by a number of parameters as illustrated in Figure 28. Moving the coupling rearwards increases the rearward amplification. This also happens if the moment of inertia of the trailer is increased. Trailer tyres with reduced cornering stiffness have quite a large impact on the dynamic behaviour. This vehicle combination type has good yaw damping.

The effect of a dolly with one axle steered was also investigated. In this dolly, the drawbar has an articulation joint not only at the front end, at the coupling, but also at its rear end. The first axle of the dolly is steered proportionally to the articulation angle between the drawbar and the dolly. The purpose is to reduce the swept path width, but it has a negative impact on the dynamic stability. One critical item of this design is that the stability is completely dependent on the damping between the drawbar and the dolly. The damping has to be provided by special dampers. In this study a damping rate of 50000 Nms/rad was assumed. If the damping approaches zero, instability of the vehicle combination will occur.

Figure 28 – Effect on rearward gain

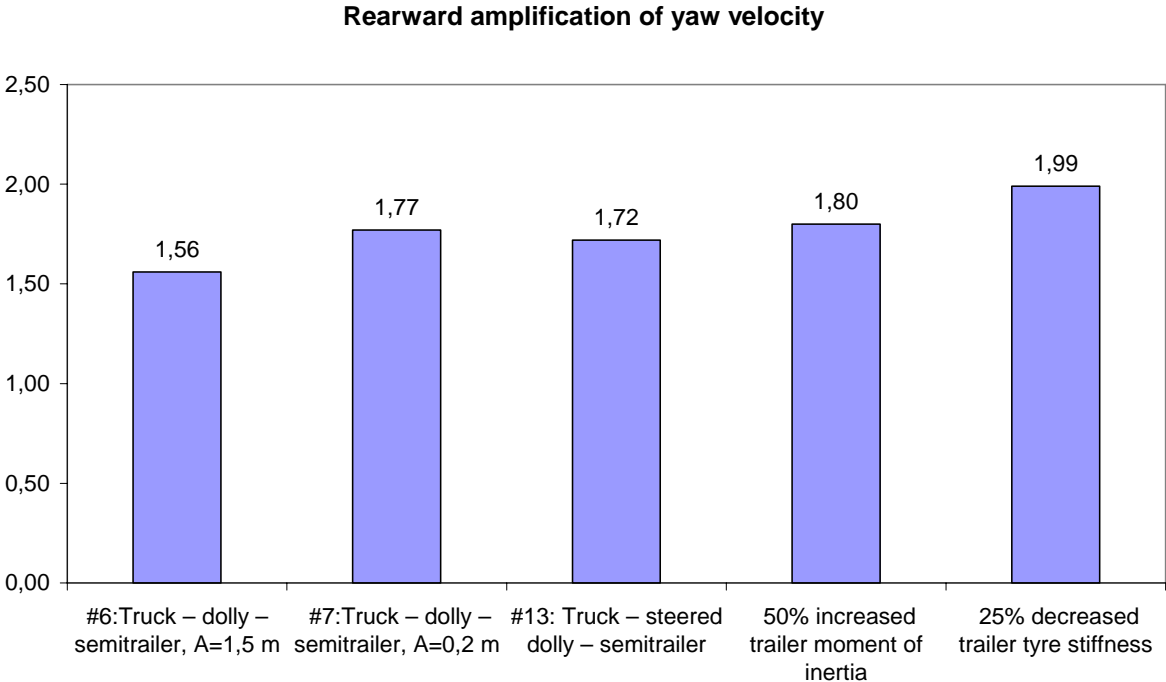
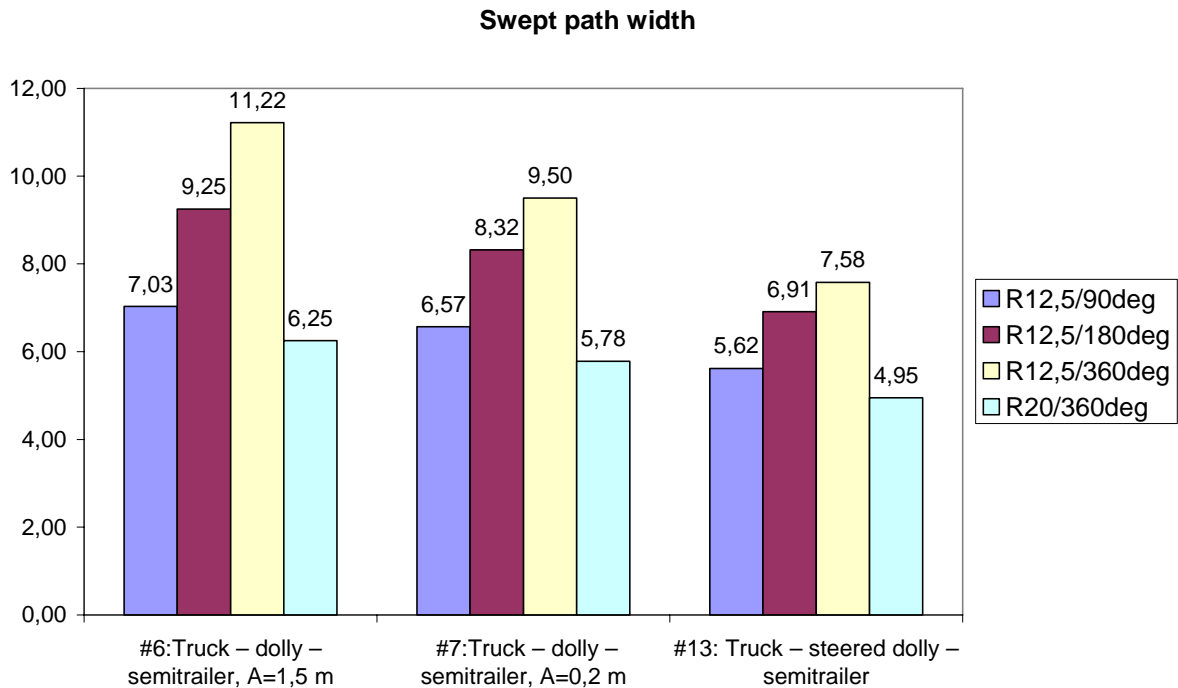

Figure 29 shows that the more rearward position of the coupling reduces the offtracking of the combination, and that the steered dolly reduces the offtracking significantly.

Figure 29 – Effect on offtracking



9.6 B-double (#8)

The B-double combination has a good inherent dynamic stability. Two respectively three axles on the B-semitrailer have just a small effect on the dynamic behaviour, as Figure 30 shows. The effect of force-steered axles of the B-semitrailer was also investigated. The steer angle is then proportional to the articulation angle of the fifth wheel. The steered axles reduce the effective wheelbase of the B-semitrailer. This has a large effect on the dynamic stability. Self-steered axles would of course have a dramatically negative effect.

The purpose of the steered axles is to reduce the offtracking. Figure 31 shows this effect. One steered axle has however only a marginal effect, while two steered axles have a good effect. The drawback with conventionally steered axles is that there will be both an entry tail swing and sometimes an exit tail swing. This is particularly critical, as the driver cannot see the outer corners of the trailers in a turn.

Figure 30—Effect on rearward gain

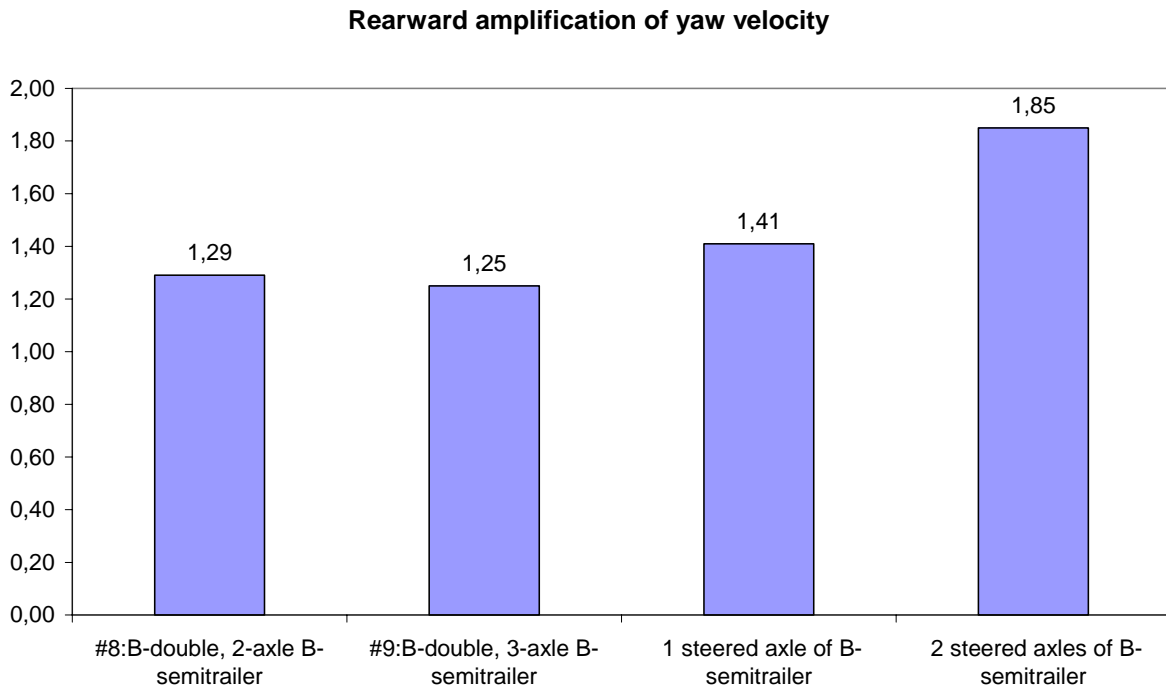
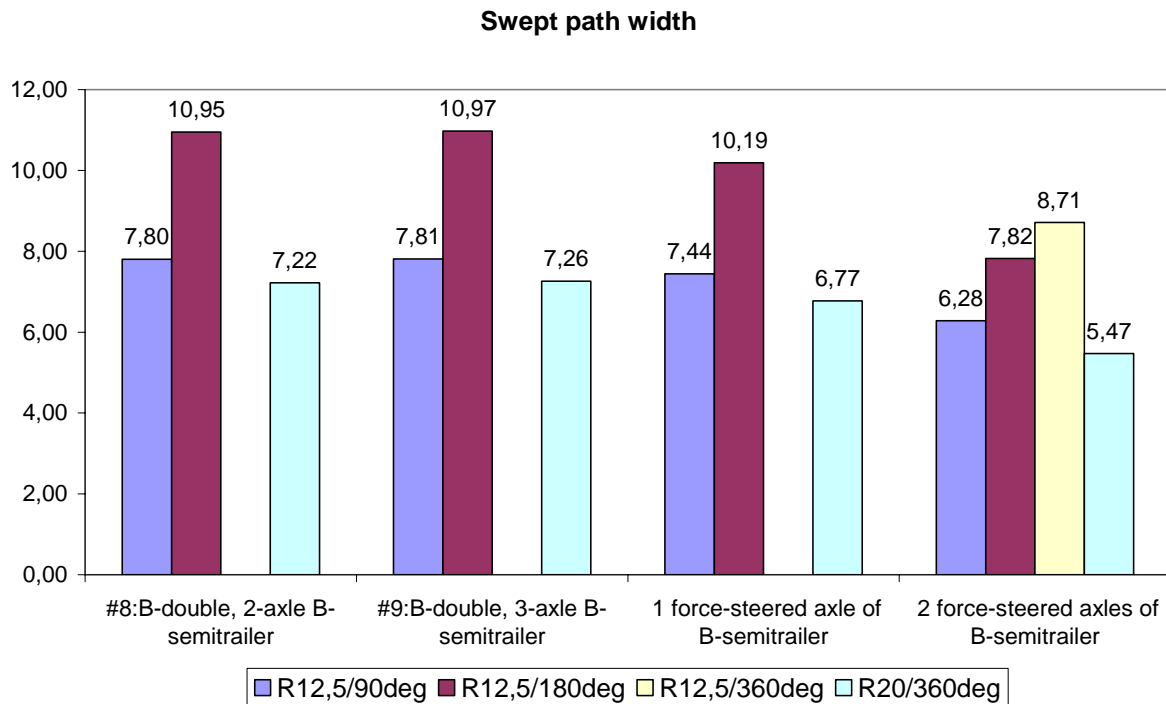

Figure 31—Effect on offtracking



9.7 Double centre-axle trailer (#12)

This vehicle combination has more forward locations of the couplings than on the other combinations. It has rather a high amplification factor. If the couplings are moved rearwards, both on truck and trailer, this will further increase the gain, as appears in Figure 32. Moving 3 t load to each trailer from the truck also reduces the stability. A static load on the coupling improves the situation. It is also normally the case to have at least 500 kg vertical load on the coupling. One way of improving the stability is to introduce damping in the articulation joints.

Figure 32—Effect on the rearward gain

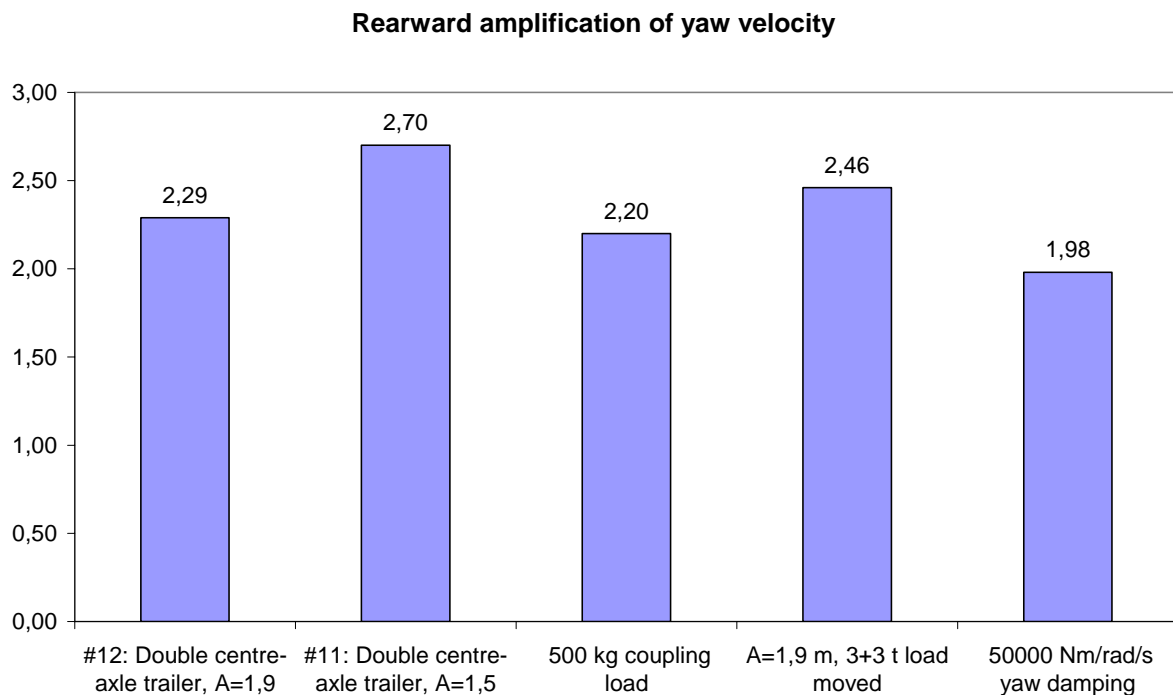

As there are centre-axle trailers in this combination, lack of yaw damping may be a potential problem. Figure 33 shows the yaw damping at a velocity of 80 km/h for various parameter variations. In the baseline condition the damping is 0,16, but at a speed of 116 km/h the damping is zero and instability occurs. Reducing the coupling distance with 0,4 m to 1,5 m, as well as moving 3 t load from the truck to each trailer, will reduce the damping significantly. The zero-damping speed will then be 95 km/h respectively 96 km/h. Loading the couplings vertically improves the damping, and the zero-damping speed with moved load is 111 km/h. Damping in the articulation joints, finally, naturally increases the damping and the zero-damping speed, in this case to 132 km/h. It is sufficient to apply the damping only in the coupling on the truck. A damping rate of 50000 Nms/rad is assumed. Damping in the joint between the trailers gives only a very small additional contribution to the yaw damping of the combination.

Figure 33—Effect on yaw damping

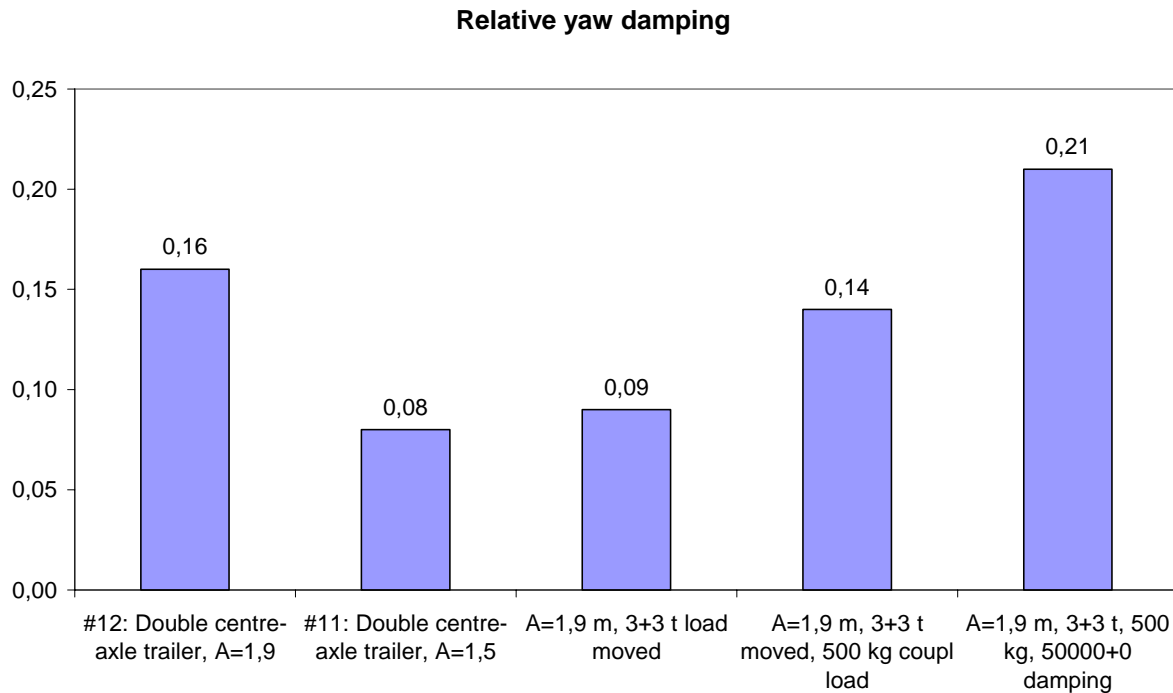

Figure 34 illustrates an interesting effect. Reduced maximum friction between road and tyres, by 60 %, has a very large effect on the stability and increases the yaw velocity gain very much. This can however not be seen on the lateral acceleration gain, which even goes down. This is due to that the trailers move with large amplitudes but the tyre forces are not large enough to generate high accelerations. This gives further confirmation that lateral acceleration gain cannot always be used as a performance measure of dynamic stability.

Figure 35 shows that, as expected, the more rearward position of the coupling gives smaller offtracking.

Figure 34—Comparison between yaw and acceleration response

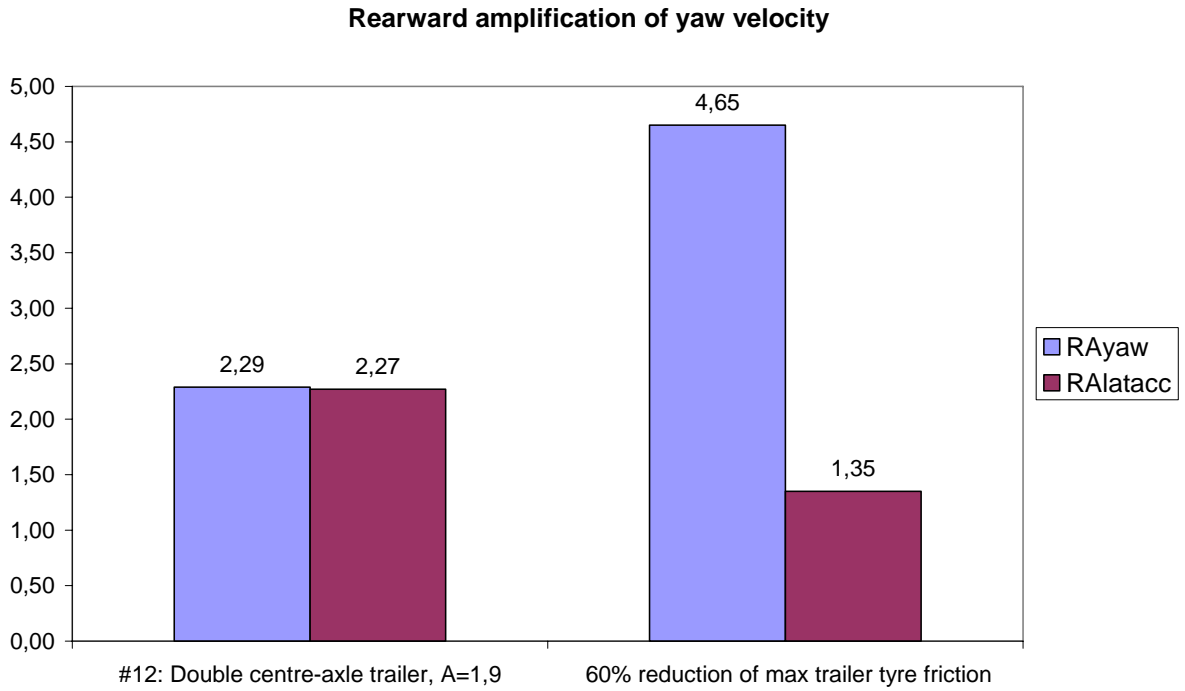
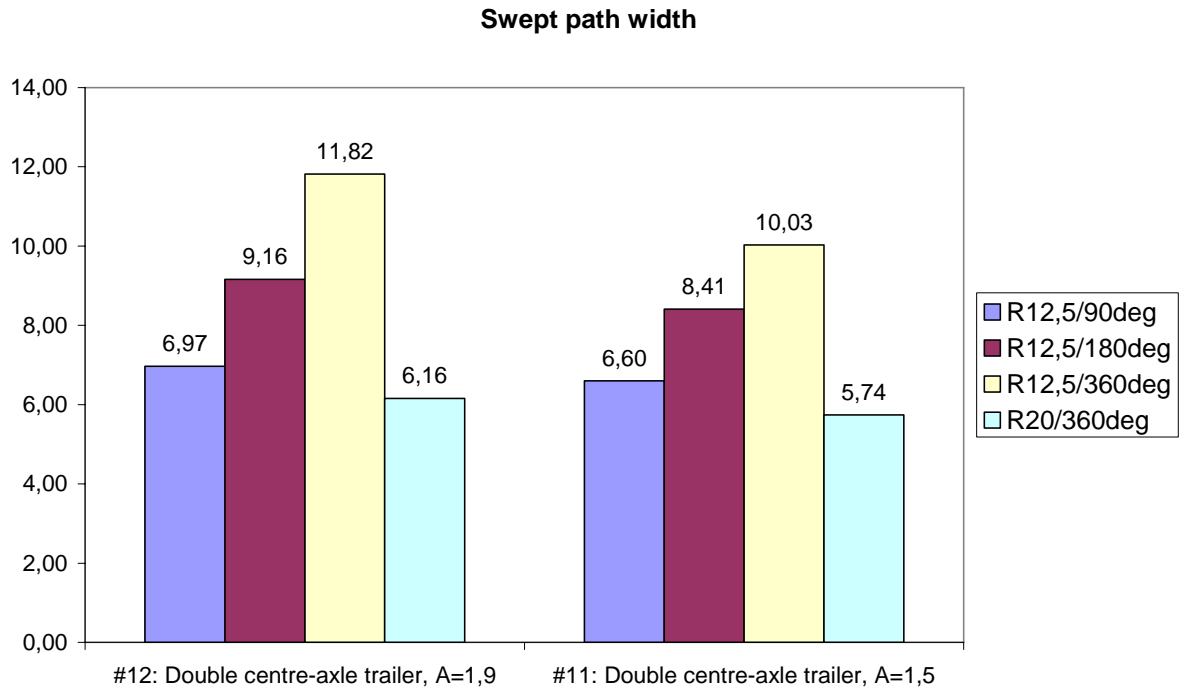

Figure 35—Influence from coupling position on offtracking



9.8 Summary of parameter study

Although each type of vehicle combination has its specific dynamic behaviour, some general conclusions regarding the effect of various parameters may be drawn.

9.8.1 Number of articulation joints

More articulation joints increase in general the rearward amplification and normally reduce the offtracking. The behaviour of the vehicle combination depends however on a large number of parameters, and it may very well occur that a vehicle combination with for example three articulation joints is more stable than another one with only two articulation joints.

9.8.2 Coupling position

The position of the coupling in relation to the rear axles has a large influence on stability. The closer the coupling is to the rear axles, the better the dynamic stability of the vehicle combination. For the offtracking it is however just the opposite. The swept path width becomes smaller when the coupling is moved towards the rear of the vehicle.

The position of the coupling is obviously important for the interchangeability between vehicle units in vehicle combinations. In order to have full flexibility, the coupling distance should be the same on all relevant vehicle units. A distance of 1,5 m between the coupling axis and the rear end is appropriate. There is however no common practise in Europe, and there are different needs. Trucks used in distribution traffic sometimes have a need of a tail lift, which is difficult to combine with a forward-mounted coupling. In some vehicle combinations however, the location of the coupling should be restricted. For combinations with one centre-axle trailer, coupled to a rigid truck or to a semitrailer, the coupling on the truck or trailer should always have a coupling distance of at least 1,5 m. In a double centre-axle trailer combination, the coupling distance should be at least 1,9 m in order to get sufficient stability.

The vertical down-load from centre-axle trailers on the couplings should not be less than 500 kg in order to obtain sufficient yaw damping.

9.8.3 Drawbar length

A longer drawbar improves the stability. In a combination with full trailer, this requires normally a more forward position of the coupling, which also has a positive effect. There will thus be a double effect. The drawback with a longer drawbar is that the offtracking increases.

9.8.4 Trailer wheelbase

Increasing the wheelbase of trailers, of all kinds, has a significant stabilizing effect on vehicle combinations. As increasing the wheelbase of a centre axle trailer, normally also increases the coupling distance, this gives a double effect. Longer wheelbases, on the other hand, increase the swept path width.

9.8.5 Steered trailer axles

The purpose of steered axles is to reduce wheel scrubbing and offtracking. Steered trailer axles, self-steered or force-steered ones, may reduce the swept path width of the vehicle combination substantially. They do however impair the dynamic stability significantly. Self-steered trailer axles, in particular, have a negative effect and shall therefore operate only at low speeds. Force-steered axles, as well, increase the rearward gain and should therefore not steer at high speeds.

9.8.6 Mass distribution

Moving the load rearwards in the combination, e.g. from the towing vehicle to the trailer, impairs the dynamic stability. Moving the centre of gravity of the trailer rearwards has the same effect.

9.8.7 Trailer tyre properties

Tyre characteristics are very important for the dynamic behaviour of a vehicle combination. For a correct comparison, it is therefore crucial to have equal tyres on different vehicle combinations. Reduced cornering stiffness of the trailer tyres increases the rearward gain significantly.

10 Conclusions

Many countries throughout the world use longer vehicle combinations than are currently used for international transports in Europe. Modular loading units are used to a certain extent. Although the authorized gross combination weights are higher than in Europe, the axle loads are always lower. This is advantageous for the infrastructure.

Congestion on European roads is a growing problem. Estimates made by the EU Commission, show a large increase of the amount of transported goods in coming years. The railroad has no potential for all this increase, so the main part will be carried out by road transports. The modular concept, also called the European Modular System, EMS, offers a possibility to make both road transports and intermodal transports more efficient and environmental friendly.

There have been concerns about the traffic safety of long vehicle combinations. The truth is however, that longer vehicle combinations have in general better dynamic stability than shorter vehicle combinations.

Obviously long vehicle combinations require larger space than short ones in various manoeuvres. Long modular vehicle combinations are however not supposed to be driven on the whole road network, but on roads suited for this type of vehicle combinations. Although Directive 96/53 EC does not require fulfilment of any low-speed offtracking performance, single countries have found it appropriate to set up such performance-based standards. It is then important that the specified manoeuvre is relevant for the driving conditions of long modular vehicle combinations. Negotiating a very tight 360-degree turn does not belong to this category. A 90-degree turn on a 12,5 m outer radius is more appropriate. The required swept path width may be adapted to the actual infrastructure. For reasons of simplicity, the demands on SPW should be coupled to geometrical demands, so that, if certain dimensions of the vehicle combinations are fulfilled, they shall be deemed to comply with the requirements.

Steered axles of the trailers are naturally reducing the swept path width of the combination. Self-steered axles in particular, but also force-steered axles, degrade however the dynamic stability, and the axles shall therefore be steering just for low speeds. Introducing steered axles on the trailers is however against the principle of the modular concept. It is then no longer standard units that are coupled together. A further possibility is to steer the trailer axles actively in such a way that all axles follow the same path. In this way the swept path width would be minimized and the dynamic stability very good at the same time. Technically this is possible, but, currently, hardly feasible in real transportations.

The positions of the couplings have a large influence on both stability and offtracking, unfortunately in opposite directions. One theoretical possibility to overcome this conflict would be to have a variable coupling position. This could be achieved by automatically moving the

coupling rearwards in turns at low speeds. Another possibility could be to use a four-bar linkage system, thus creating a virtual coupling position. Two couplings, with a variable distance between them, would then be required. At high speeds the couplings would be far apart, thereby increasing the stability, and in turns at low speeds, the two couplings would automatically be moved towards each other. Again, these solutions are, currently, hardly feasible in real operations.

The traction requirement in Directive 96/53 EC, i.e. at least 25 % of the total weight on driving axles, may be fulfilled with one driving axle up to a GCW of 46 t. If single countries that have the need will apply this requirement for modular combinations, more than one driving axle will be required, if the GCW exceeds 46 t.

The most important results may be summarized as follows:

- The modular concept has a large environmental impact with a substantial reduction of the emission of CO₂ and other harmful gases.
- Long modular vehicle combinations contribute to ease the congestion problem on European motorways.
- The modular concept creates prerequisites and facilitates for intermodal transports on railroads.
- The road wear from current modular vehicle combinations and in particular from suggested prospective combinations is typically less than with current European vehicle combinations.
- Modular combinations have better dynamic stability than many conventional European combinations.
- For good dynamic stability, the coupling should be moved forward. Couplings for centre-axle trailers shall have a coupling distance of not less than 1,5 m. Combinations with two centre-axle trailers shall have a coupling distance of not less than 1,9 m.
- For all vehicle combinations, there is a contradiction between good stability and small low-speed offtracking.
- When performance-based standards on swept path width are used, a 90-degree turn on a 12,5 m outer radius is recommended.
- Three-axle tractors are necessary in order to avoid overloading of the driving axle, both for conventional European combinations and for modular combinations.

11 References

1. TFK Report 2002:6E: Improved Performance of European Long Haulage Transport, 2002.
2. Confederation of Swedish Enterprise: Fewer trucks improve the environment, 2004.
3. TFK Report 2007:2E: European Modular System for road freight transport – experiences and possibilities, 2007.
4. ISO 14791. Road vehicles—Heavy commercial vehicle combinations and articulated buses—Lateral stability test methods, 2002.

NVF
Vejdirektoratet
Niels Juels Gade 13
Postboks 9018
DK-1022 København K
Danmark
Telefon +45 72 44 33 33 telefax +45 33 32 98 30
E-post: nvf@vd.dk

NVF
c/o Vägförvaltningen
Postbox 33
FIN-00521 Helsingfors
Finland
Telefon +358 204 22 2575 telefax +358 204 22 2471
E-post: nvf@finra.fi

NVF
c/o Landsverk
Box 78
FO-110 Torshavn
Færøerne
Telefon +298 340 800 telefax +298 340 801
E-post: lv@lv.fo

NVF
c/o Vegagerdin
Borgartun 7
IS-105 Reykjavik
Island
Telefon +354 522 1000 telefax +354 522 1009
E-post: hreinn.haraldsson@vegagerdin.is

NVF
c/o Vegdirektoratet
Postboks 8142 Dep
NO-0033 Oslo
Norge
Telefon +47 22 07 38 37 telefax +47 22 07 37 68
E-post: publvd@vegvesen.no

NVF
c/o Vägverket
SE-781 87 Borlänge
Sverige
Telefon +46 243 757 27 telefax +46 243 757 73
E-post: nvf@vv.se

The NVF-reports may be ordered from any of the NVF-secretariats above.
There is an updated record of NVF-reports on <http://www.nvfnorden.org>.

